

***POWERBOSS***<sup>®</sup>

**BADGER**<sup>®</sup> SWEEPER

SW/62E, SW/62IC

**OPERATION,  
MAINTENANCE,  
& TROUBLESHOOTING**

***Shrinkwrap protective cover  
Please Discard***

***AAR POWERBOSS, INC.***

ANDERSON & TAYLOR STREETS / P.O. BOX 1227  
ABERDEEN, NORTH CAROLINA 28315 U.S.A.  
(910) 944-2167 / FAX: (910) 944-7409



**NOVEMBER '94**



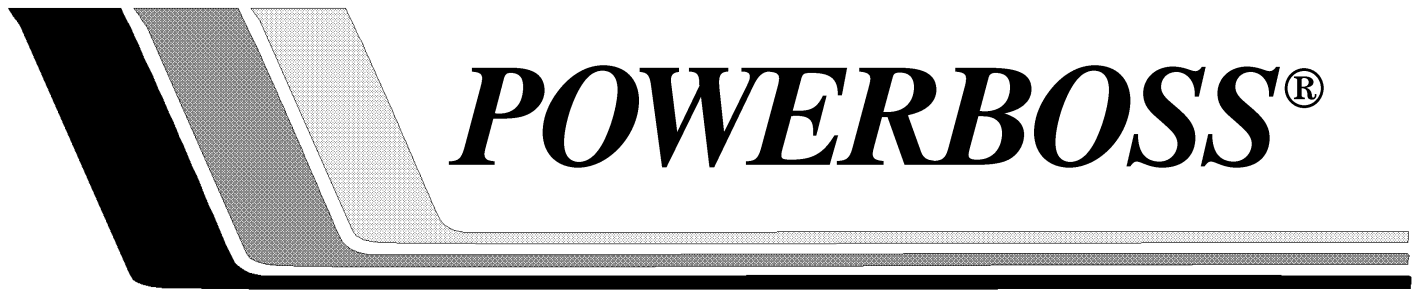

# ***POWERBOSS***<sup>®</sup>

## **BADGER**<sup>®</sup> SWEEPER

SW/62E, SW/62IC

# **OPERATION, MAINTENANCE, & TROUBLESHOOTING**

***AAR POWERBOSS, INC.***

ANDERSON & TAYLOR STREETS / P.O. BOX 1227  
ABERDEEN, NORTH CAROLINA 28315 U.S.A.  
(910) 944-2167 / FAX: (910) 944-7409



## **NOVEMBER '94**

All information contained in this manual is current at the time of printing. However, due to constant updates and improvements we reserve the right to make changes at any time without notice.

**© *Copyright 1994, AAR POWERBOSS, INC.***

All rights reserved. This manual may not be copied or reproduced in any form, without the written permission of AAR POWERBOSS, INC.

## TABLE OF CONTENTS

### SW/62E, SW/62IC

Features ..... 7  
Warranty ..... 8

### SAFETY

Safety Symbols ..... 10  
Safety Decals ..... 11  
Basic PowerBoss® Safety ..... 13

### SPECIFICATIONS

SW/62E , SW/62IC ..... 16

### COMPONENT DESCRIPTIONS

The Air Intake System ..... 20  
Circuit Breakers ..... 20  
The Fuel System ..... 20  
The Coolant System ..... 21  
The Lubrication System ..... 21  
The Hydraulics System ..... 21  
The Vacuum System ..... 22  
Rotary Trash Relocator (RTR™) ..... 22  
Brakes & Tires ..... 22

## TABLE OF CONTENTS (Cont.)

### OPERATION

Basic Operating Controls .....	23
Sweeping Controls .....	25
Debris Hopper Dump Controls .....	26
Operating Procedures .....	27
Pre-Operation Checks .....	27
Starting .....	27
Slowing and Stopping .....	28
Operating on Grades .....	28
Sweeping .....	28
Emptying the Hopper .....	29
Using the Rotary Trash Relocator (RTR™) .....	30
Transporting the Machine .....	31

### MAINTENANCE

Introduction .....	32
Preventive Maintenance Chart .....	33
Engine .....	37
Air Intake and Exhaust Systems	
Air Filter Removal .....	38
Air Filter Cleaning .....	38
Air Filter Inspection .....	38
Air Filter Installation .....	38
Electrical System	
Electrical Schematic .....	39
Battery Cleaning .....	46
Battery Replacement .....	46
Circuit Breakers .....	46
Fuel System	
Checking the LPG Fuel Filter Lock .....	47
Coolant System	
Blowing Out Radiator Fins .....	48
Reverse Flow Flushing .....	48
Lubrication	
Changing Engine Oil .....	49
Lubrication Points .....	50

## TABLE OF CONTENTS (Cont.)

<b>Hydraulics System</b>	
Filling the Fluid Reservoir .....	51
Hydraulic Fluid Viscosity Specification .....	51
Changing the Hydraulic Fluid .....	51
Changing the Hydraulic Fluid Filter .....	52
Adjusting the Directional Control Return Spring .....	52
Hydraulic Schematic .....	54
<b>Sweep Components</b>	
Broom Door Flap Inspection .....	57
Broom Door Flap Replacement and Adjustment .....	57
Main Broom Height Adjustment Test .....	57
Main Broom Height Adjustment .....	58
Main Broom Taper Adjustment .....	59
Side Broom Angle Adjustment .....	60
Side Broom Height (Wear) Adjustment .....	60
Side Broom Lift Cable Adjustment .....	60
Main Broom Replacement .....	61
Side Broom Replacement .....	62
<b>Hoppers</b>	
High Dump Hopper Removal and Replacement .....	63
Filter Removal .....	64
Filter Cleaning .....	64
Filter Replacement .....	64
Hopper Floor Clearance and Dump Adjustments .....	65
Hopper Vacuum Gasket Mount Adjustments .....	66
Hopper Flap Replacement .....	67
Hopper/Frame Seal Replacement .....	67
<b>Parking Brake</b>	
Parking Brake Adjustment .....	68
<b>Tires</b>	
Changing Solid Tires .....	69
Changing Pneumatic Tires .....	69
Miscellaneous .....	69

## TABLE OF CONTENTS (Cont.)

### TROUBLESHOOTING

Basic Machine Operating Problems (62E only) .....	70
Machine has no power .....	70
Machine has power, but not forward or reverse .....	70
Forward but not reverse, or reverse but not forward .....	70
Machine has power, but no dust control, hydraulics, or sweeping functions .....	70
Basic Machine Operating Problems (62IC only) .....	71
Engine will not start or runs roughly after start .....	71
Engine overheats .....	71
Basic Machine Operating Problems (62IC and 62E) .....	72
PowerBoss® moves slowly or does not move .....	72
PowerBoss® creeps in neutral .....	72
Sweeping Problems .....	73
Brushes do not turn or turn very slowly .....	73
Little or no vacuum in brush compartment .....	73
Loss of dust control .....	73
Sweeper unit leaving debris .....	73
Hopper does not raise or lower .....	74
Hopper does not rotate or rotates too slowly .....	74
Hydraulic System Problems .....	75
Hopper lift cylinder failure .....	75
Hydraulic control valve failure .....	75
Hydraulic motor failure .....	75
Hydraulic gear pump failure .....	75
Hydraulic variable displacement pump failure .....	76
Hydraulic system noisy .....	76



# SW/62E , SW62IC

## FEATURES

1. Dust Control Filter :50 Sq.Ft.(4.65 m<sup>2</sup>) in 62E; 92 Sq. Ft. in 62IC (8.56m<sup>2</sup>)
2. Electric Filter Shaker
3. Exhaust Air Expelled Outside Engine Compartment (only in 62IC)
4. Industrial Liquid-Cooled Engine (only in 62IC)
5. Tri-Phase Air Cleaner (only in 62IC)
6. One-Piece Unitized Steel Frame
7. Hydraulics Protection Package
8. Dual Performance Sweep Mode (only in 62IC)
9. Quick-Change Floating 36" Main Broom
10. Oversized Hopper with RTR™
11. Retractable Quick-Change Side Broom
12. Multi-Level Hopper Dumping
13. Built-In Dust PreFiltering
14. Wet Sweep By-Pass Standard
15. Instant Forward & Reverse using one Pedal
16. Excellent Maneuverability due to Compact Size & Resr Wheel Steering

**BADGER SW/62E**  
**(LIMITED) PRODUCT WARRANTY**  
**(NORTH AMERICA ONLY)**

AAR PowerBoss, Inc. warrants that the **PowerBoss** Badger SW/62E will be free from defects in material and workmanship for a period of 24 months or 1,250 operating hours from date of installation, whichever comes first. Written notice of any claimed defect must be given to AAR within the warranty period and within thirty (30) days after such defect is discovered. Liability under this warranty is limited to either replacing or repairing, at AAR's election, any part or parts deemed defective after examination by AAR or an Authorized Service Representative. The **PowerBoss** machine or any of its parts returned by customer to AAR or an Authorized Service Representative via prepaid transportation and which is found to be defective, will be repaired or replaced and returned to customer via prepaid surface transportation within the Continental U.S. On the other hand, should a part be found not defective, inspection and handling charges may be charged to the customer by AAR or an Authorized Service Representative.

For one hundred eighty (180) days from date of installation, AAR will provide repair labor, at no charge, solely through an Authorized Service Representative. Thereafter, labor will be charged.

This warranty does not extend to the **PowerBoss** machine, or its parts, that have been subject to misuse, accident or improper handling, installation, maintenance or application, nor does it extend to **PowerBoss** machine and/or parts which have been repaired or altered outside AAR's plant or the facility of Authorized Service Representative.

This warranty does not apply to routine wearable parts of the **PowerBoss** machine such as brushes, flaps, filters, seals, points, plugs, hoses or similar items. Moreover, this warranty does not extend to the **PowerBoss** machine or part replaced or repaired under this warranty.

Only replacement parts supplied by AAR are warranted for 30 days after installation.

***THE WARRANTY SET FORTH HEREIN IS IN LIEU OF AND EXCLUDES ANY AND ALL OTHER WARRANTIES, EXPRESS OR IMPLIED, ARISING BY OPERATION OF LAW OR OTHERWISE, INCLUDING, BUT NOT LIMITED TO, ANY IMPLIED WARRANTY OF MERCHANTABILITY OR FITNESS FOR A PARTICULAR PURPOSE, AND CUSTOMER WAIVES ANY OBLIGATION OR LIABILITY OF AAR ARISING IN TORT OR STRICT LIABILITY IN TORT, OR FOR LOSS OR USE, REVENUE OR PROFIT WITH RESPECT TO PowerBoss MACHINE AND/OR PARTS FOR ANY LIABILITY OF CUSTOMER TO ANY THIRD PARTY, OR FOR OTHER DIRECT, INCIDENTAL OR CONSEQUENTIAL DAMAGES.***

## **BADGER SW/62IC** **(LIMITED) PRODUCT WARRANTY**

AAR PowerBoss, Inc. warrants that the **PowerBoss** Badger SW/62 IC will be free from defects in material and workmanship for a period of 24 months or 1,200 operating hours from date of installation, whichever comes first. Written notice of any claimed defect must be given to AAR within the warranty period and within thirty (30) days after such defect is discovered. Liability under this warranty is limited to either replacing or repairing, at AAR's election, any part or parts deemed defective after examination by AAR or an Authorized Service Representative. The **PowerBoss** machine or any of its parts returned by customer to AAR or an Authorized Service Representative via prepaid transportation and which is found to be defective, will be repaired or replaced and returned to customer via prepaid surface transportation within the Continental U.S. On the other hand, should a part be found not defective, inspection and handling charges may be charged to the customer by AAR or an Authorized Service Representative.

For one hundred eighty (180) days from date of installation, AAR will provide repair labor, at no charge, solely through an Authorized Service Representative. Thereafter, labor will be charged.

This warranty does not extend to the **PowerBoss** machine, or its parts, that have been subject to misuse, accident or improper handling, installation, maintenance or application, nor does it extend to **PowerBoss** machine and/or parts which have been repaired or altered outside AAR's plant or the facility of Authorized Service Representative.

This warranty does not apply to routine wearable parts of the **PowerBoss** machine such as brushes, flaps, filters, seals, points, plugs, hoses or similar items. Moreover, this warranty does not extend to the **PowerBoss** machine or part replaced or repaired under this warranty.

Only replacement parts supplied by AAR are warranted for 30 days after installation.

The warranty for optional engines shall be limited to the warranty extended to AAR by the supplier.

***THE WARRANTY SET FORTH HEREIN IS IN LIEU OF AND EXCLUDES ANY AND ALL OTHER WARRANTIES, EXPRESS OR IMPLIED, ARISING BY OPERATION OF LAW OR OTHERWISE, INCLUDING, BUT NOT LIMITED TO, ANY IMPLIED WARRANTY OF MERCHANTABILITY OR FITNESS FOR A PARTICULAR PURPOSE, AND CUSTOMER WAIVES ANY OBLIGATION OR LIABILITY OF AAR ARISING IN TORT OR STRICT LIABILITY IN TORT, OR FOR LOSS OR USE, REVENUE OR PROFIT WITH RESPECT TO PowerBoss MACHINE AND/OR PARTS FOR ANY LIABILITY OF CUSTOMER TO ANY THIRD PARTY, OR FOR OTHER DIRECT, INCIDENTAL OR CONSEQUENTIAL DAMAGES.***

(April 1993)

## SAFETY SYMBOLS

Five symbols are used throughout this manual to emphasize various levels of safety information. These symbols and the meaning of each are listed below.



**DANGER:** To warn of immediate hazards which will result in severe personal injury or death.



**WARNING:** To warn of hazards or unsafe practices which could result in severe personal injury or death.

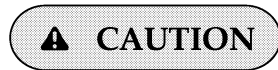

**CAUTION:** To warn of hazards or unsafe practices which could result in minor personal injury.



**ATTENTION!** To warn of practices which could result in extensive equipment damage.



**NOTE:** To direct your attention to important equipment information or special instructions for preventing damage to equipment.

Symbols at the top of the list are the strongest warnings. However, all symbols represent important information which should be observed to protect you and others from harm and injury, and to prevent damage to equipment.

## SAFETY DECALS

Decals directly attached to various parts of the sweeper are highly visible safety reminders which should be read and observed. Make sure the decals are replaced if they become illegible or damaged. The decal below is located in the drive compartment. Other safety decals on your machine appear on the next page.

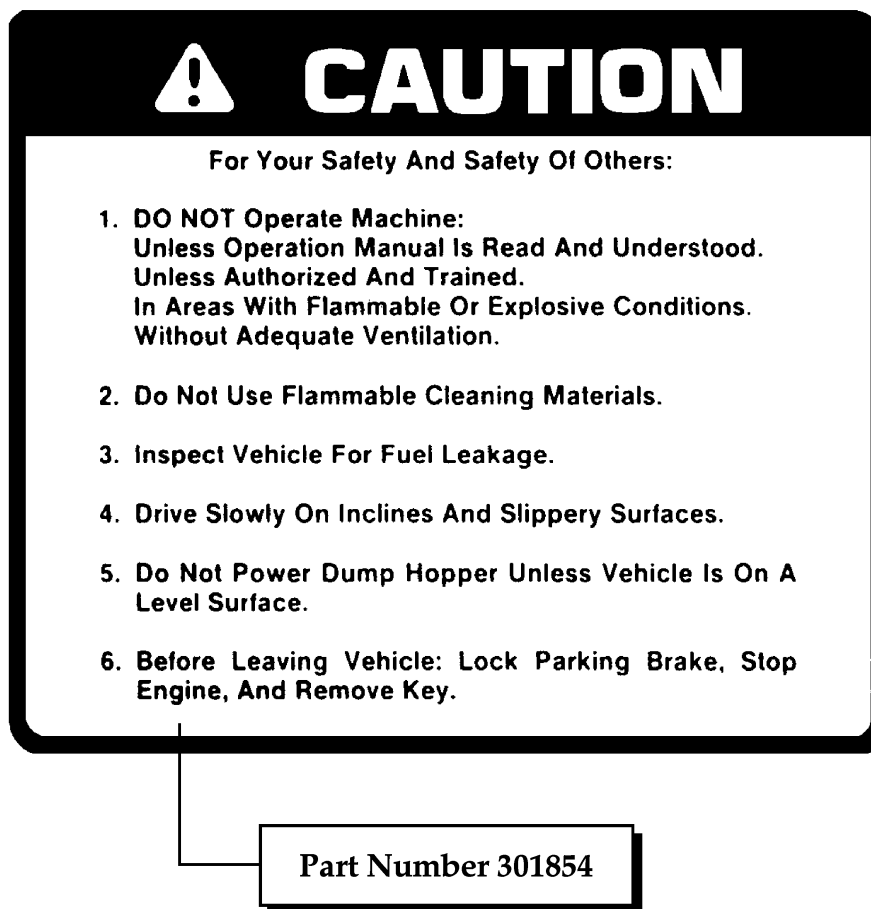

**! CAUTION**

For Your Safety And Safety Of Others:

1. **DO NOT Operate Machine:**  
Unless Operation Manual Is Read And Understood.  
Unless Authorized And Trained.  
In Areas With Flammable Or Explosive Conditions.  
Without Adequate Ventilation.
2. Do Not Use Flammable Cleaning Materials.
3. Inspect Vehicle For Fuel Leakage.
4. Drive Slowly On Inclines And Slippery Surfaces.
5. Do Not Power Dump Hopper Unless Vehicle Is On A Level Surface.
6. Before Leaving Vehicle: Lock Parking Brake, Stop Engine, And Remove Key.

Part Number 301854

Located at the Impeller :

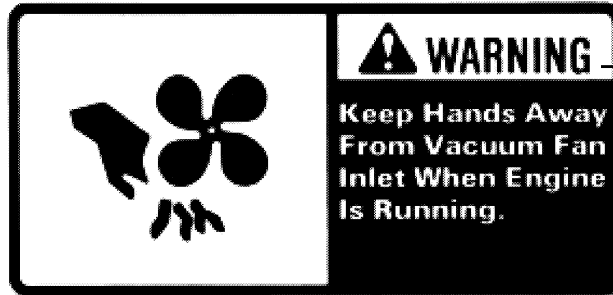

Part Number 301729

Located on the high dump hopper:

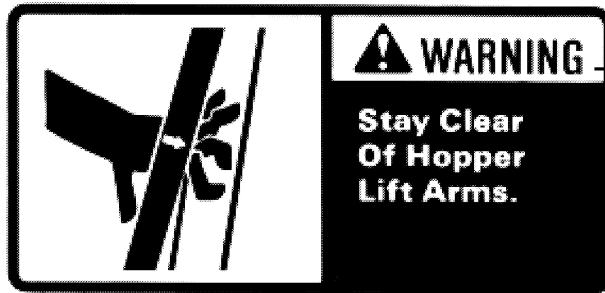

Part Number 301732

Located on the shroud of the radiator (62IC):

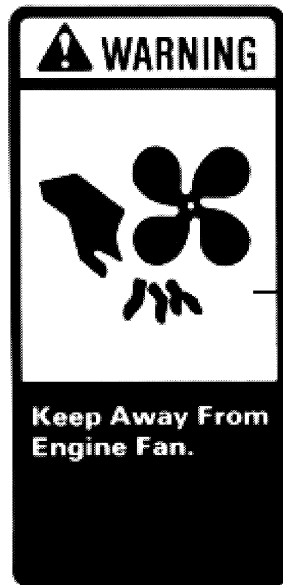

Part Number 301733

## BASIC PowerBoss® SAFETY

PowerBoss sweepers should never be operated unless: 1. the operator is trained and authorized to operate the equipment and, 2. the equipment is free of malfunctions. Malfunctioning equipment should be removed from service.

### DANGER

1. Keep cigarettes, matches, and all other flame sources away from the sweeper. Gasoline, LP gas, and diesel fuel are highly flammable. Lead acid batteries are equally dangerous due to the highly explosive hydrogen gas they emit.

### WARNING

1. Before starting the engine, make sure that:
  - You are securely seated in the operator's seat.
  - The parking brake is locked.
  - The directional control pedal is in neutral.
  - The throttle is in idle. (For 62IC models)
  - Hydraulic controls are in OFF position.
2. During operation:
  - Keep your hands and body clear of moving parts, especially when the hopper or lift arms are partially or fully raised.
  - Make sure others in the area stay clear of the equipment and moving parts.
  - Never attempt to dump debris from a dock or mezzanine. Dump from ground level only.
3. When leaving the sweeper unattended:
  - Place the controls in OFF position.
  - Set the parking brake.
  - Shut off the machine.

4. During cleaning and maintenance:
  - Always shut off all power and set the parking brake before servicing.
  - Never use detergents or cleansers that are flammable or combustible.
  - Never inflate a pneumatic tire without using a safety cage.
  - Do not attempt any impeller adjustment unless you have turned off the machine. Never place your hands near the intake hoses or inlet when the engine is running (on 62IC models).
  - Always engage the safety arm before getting under the hopper. Do not rely on the hydraulic cylinder to keep the hopper raised.
  - Never test for hydraulic hose leaks using your hand or any other part of your body. High pressure leaks can be very dangerous and should only be checked using a piece of paper.
5. When servicing or repairing the fuel system (on 62IC models):
  - Work in a properly ventilated area, do not smoke, or allow an open flame near the fuel system.
  - Never bypass safety components unless you are testing them.
  - Never bypass the fuel filter lock, except when testing them (and always reconnect them after testing).
  - Wear gloves to disconnect the tank coupling.
6. (on 62 IC models) Do not operate an LPG powered sweeper when any component in the fuel system is malfunctioning or leaking.
7. Replace any defective safety components before operating the sweeper.

**▲ CAUTION**

1. Do not drive with the hopper in the raised position except the few feet necessary to position the hopper over the dumpster or receptacle. Driving with the hopper raised reduces visibility and creates conditions for striking overhead objects, throwing the machine off-balance, and other hazards.



2. Travel slowly on grades.
3. Place a block or chock behind the wheels when parking on inclines.
4. Use special care when traveling on wet surfaces.
5. Observe all proper procedures for operation and maintenance of the sweeper, as outlined in this manual.
6. Remain alert at all times to people and equipment in and around your area of operation.

**ATTENTION!**

1. Do not operate the #2 RTR lever before the #1 light illuminates.
2. Never push or tow a machine faster than specified.

## SW/62E

Motors/Batteries	1.9 HP (1.43 kw) accessory motor powers brushes, vacuum fan and hopper lift. 1.2 HP (0.9 kw) propels motor. 36-volt system. 295 AH and 440 AH heavy-duty batteries are optional.
Frame	Unitized steel frame with 1.5-inch (38 mm) x 5-inch (127 mm) box section reinforcement.
Drives	Direct drive of rear wheel through gearbox by electric motor with solid state speed control. Variable speed to 6 mph (10 kmh). Main brush and vacuum fan are belt-driven.
Steering	Standard automotive recirculating ball type through rear wheel.
Turning Radius	Left Hand - 59.50-inches (234.25 mm). Right Hand - 77.00-inches (303.15 mm). U-Turn - 92.38-inches (363.70 mm).
Sweep Path	48-inch (1200 mm) Sweep Path Including Side Brush
Sweeping Coverage	126,700 sq. ft. (11,400 m <sup>2</sup> ) per hour based on a 48-inch (1200 mm) path at 6 mph (10 kmh) with 6-inch (152 mm) overlap. At typical sweeping speed of 4 mph (6 kmh) with 6-inch (152 mm) overlap, covers up to 74,000 sq. ft. (6800 m <sup>2</sup> ) per hour.
Sweeping Brushes	Main Broom: 14-inch (356 mm) diameter, 36-inch (914 mm) length. Cylindrical, one-piece plastic core disposable runs at constant RPM. Five minute broom change. Raised and lowered from operator compartment. Floats for uneven surfaces. Adjustment for pressure, wear.  Side Brush: 17-inch dia. (432 mm) rotary, one-piece disposable. Quick-change in seconds. No tools required. Bumper protected. Features retractable housing that swings away from obstructions. Adjustment for angle, pressure and wear.

**SW/62E (CONT.)**

Vacuum System	Fully enclosed, positive sealed, reusable panel filter. 50 sq. ft. (4.65 m <sup>2</sup> ) of filtering area. High-volume, low-pressure 9-inch (229 mm) dia. impeller provides constant air flow. Filter cleaned with electric shaker.
Debris Hopper	10 cu. ft. (.2831 m <sup>3</sup> ); holds up to 650-lbs. (295 kg). Multi-level hydraulic high-dump up to 60-inches (1524 mm). Features RTR™ (Rotary Trash Relocator) as standard item. Also features Remote (operates from driver's seat) Wet Sweep By Pass as standard item.
Controls	Operator controls all functions of sweeping and debris disposal while seated. Instant forward, reverse and braking using one pedal. Foot and hand lever activated emergency/parking brake.
Tires	Front - Two 18-inch (457 mm) Solid or non-marking solid. Rear - One 16-inch (406 mm) Solid or non-marking solid.
Weight	Net: 2330-lbs. (1057 kg) with 295 AH batteries/2500-lbs. (1134 kg) with 440 AH heavy-duty batteries. Add 250-lbs. (114 kg) for shipping weight. All approximate.
Dimensions	Machine: Length - 77.5-inches (1968 mm). Width - 48-inches (1219 mm). Height - 53-inches (1345 mm). 83-inches (2108 mm) with overhead guard/cab.  Battery Compartment: (Two battery compartments of equal size) Length - 19.75-inches (77.75 mm). Width - 12.06-inches (47.48 mm). Height - 23.06-inches (90.79 mm). <i>*Note - Height measurement denotes maximum height of battery case that can be used with machine.</i>

## SW/62 IC

Engine	<p>Kubota 24.5 HP (18.2 kw), 3 Cyl Liquid-Cooled Gasoline                  Kubota 22 HP (16.4 kw), 3 Cyl Liquid-Cooled LPG                  Kubota 20 HP (14.9 kw), 3 Cylinder Liquid-Cooled Diesel</p> <p>8-gallon (30 liter) Gas Tank. Electric Start / 12-volt Battery.</p> <p>40 Amp Alternator Standard.</p>
Frame	<p>Unitized steel frame with 1.5-inch (38 mm) X 5-inch (127 mm) box section reinforcement. Heavy-duty, shock-mounted steel wraparound bumper.</p>
Drives	<p>Hydraulically-driven through Rear Wheel. Variable Speeds to 6 MPH (9.66 kmh). Main Broom, Side Broom, Hopper Dump and Vacuum Impeller are Hydraulically Driven.</p>
Steering	<p>Standard automotive recirculating ball-type through rear wheel.</p>
Turning Radius	<p>Left Hand - 58 inches (1471 mm)                  Right Hand - 56 inches (1421 mm)                  "U" Turn - 110.5 inches (2804 mm)</p>
Sweep Path	<p>53" (1345 mm) Sweep Path Including Side Brush</p>
Sweep Coverage	<p>124,080 Sq. Ft. (11,527 m<sup>2</sup>) Per Hour based on a 53-inch Path at 6 MPH (9.66 kmh) with 6-inch (152 mm) overlap. At typical sweeping speed of 4 mph (6 kmh) with 6-inch (152 mm) overlap, covers up to 82,720 Sq. Ft. (7,685 m<sup>2</sup>) per hour.</p>
Sweeping Brooms	<p>Main Broom: 14-inch (355 mm) diameter, 36-inch (914 mm) length. Cylindrical, one-piece plastic core disposable runs at constant RPM. Five minute broom change. Raised and lowered from operator compartment. Floats for uneven surfaces. Adjustable for pressure and wear.</p>

## **SW/62 IC (CONT.)**

Side Broom: 24-inch dia. (610 mm) rotary, one-piece disposable. Quick-change in seconds. No tools required. Bumper protected. Features retractable housing that swings away from obstructions. Adjustment for pressure and wear.

**Vacuum System**

Fully-enclosed, positive-sealed, reusable panel filter. 92 Sq. Ft. (8.56 m<sup>2</sup>) of filtering area. Filter cleaned with standard electric shaker motor. High-volume, low-pressure 9-inch (228 mm) dia. impeller provides constant air flow. Wet-sweep Bypass feature is standard.

**Debris Hopper**

10 Cu. Ft. (0.28 m<sup>3</sup>) holds up to 650 lbs. (295 kg) multi-level high dump up to 60-inches (1523 mm). Features RTR™/ Rotary Trash Relocator system.

**Controls/ Accessories**

Operator controls all functions of sweeping and debris disposal while seated. Instant forward and reverse using one pedal. Foot pedal travel brake. Hand-activated emergency/ parking brake. Head- and tail-lights. Horn button.

**Instruments**

Fuel gauge, hour meter, high engine temperature indicator light, low engine oil pressure indicator light and battery charge indicator light. RTR®/ Rotary Trash Relocator indicator lights.

**Tires**

Front - Two 18-inch (457 mm) Pneumatic, solid, or soft shoe  
Rear - One 16-inch (406 mm) Pneumatic, solid, or soft shoe

**Weight**

Net - 2,550 Lbs. (1159 kg).  
Shipping - 2,950 Lbs. (1340 kg).  
All approximate.

**Dimensions**

Length - 77.5-inches (1967 mm)  
Width - 53-inches (1345 mm)  
Height - 53-inches (1345 mm)  
79.5-inches (2018 mm) with overhead guard

## COMPONENTS

### THE AIR INTAKE SYSTEM

(For 62 IC models) Engines are equipped with a dry cartridge type air filter with a rubber dust cup in the housing. The filters are accessible for easy removal and cleaning.

All engines have tangential inlet air filters.

### THE ELECTRICAL SYSTEM

#### Circuit Breakers

There are five circuit breakers located to the left of the driver.

(For 62E)

1. Ignition Switch, Safety Switch on Clip, Main Contactor Inside Control Box
2. Battery Condition/ Hourmeter, Horn
3. Filter Shaker Motor
4. Headlights, Taillights
5. RTR™ Indicators

(For 62IC)

1. Headlights
2. Curb Broom, Horn, Filter Shaker
3. RTR™ indicators, Fuel Gauge, Hourmeter
4. Oil Pressure Indicator, Water Temperature Indicator, Charge Indicator
5. Main (Ignition Switch - Battery, Starter - Battery)

### THE FUEL SYSTEM (For 62IC Models)

#### Gasoline

Major fuel system components for gasoline-fueled engines are:

- fuel tank
- fuel filter
- mechanical fuel pump
- carburetor
- manually operated carburetor choke

#### Liquid Propane Gas (LPG)

Major fuel system components for LPG-fueled engines are:

- fuel tank
- pressure relief valve/ fuel filter
- vacuum lock-off valve
- combination water heated vaporizer and primary regulator
- combination carburetor and secondary regulator

Diesel

Major fuel system components for diesel-fueled engines are:

- fuel tank
- fuel water trap
- fuel filter
- fuel lift pump
- fuel injection pump
- fuel injectors

#### THE COOLANT SYSTEM (For 62IC)

*Radiator Capacity:* Gas/LPG :1.2 qts, US, Diesel: 1.9 qts, US ; *Total System Capacity:* Gas/LPG: 2.5 qts.,US, Diesel: 3.25 qts, US circulates through hoses and engine block which bring the total system capacity to 3.25 quarts.

A spring-loaded valve in the radiator pressure cap, designed to open at 13 psi, closes the outlet to the overflow pipe.

#### THE LUBRICATION SYSTEM

Grease fittings supply lubrication to:

- steering cylinder pivot points
- steering fork assembly
- pillow blocks supporting dump arms (on 62IC)

#### THE HYDRAULICS SYSTEM

Hydraulic fluid is pumped from a one-gallon capacity reservoir (62E) and a six-gallon capacity reservoir (62IC).

The fluid passes through a 100 mesh suction strainer into supply lines which circulate fluid through two systems: the propulsion system and the accessory system. In the 62E, the hydraulic pump is controlled by an electric auxiliary drive motor and is activated with an auxiliary power switch located on the operator's console.

Fluid returns through a heat exchanger and a filter equipped with a condition gauge.

Propelling System

For the 62E, the major component of the propelling system is a potentiometer. The potentiometer regulates fluid to drive the wheel motor which controls the forward and reverse speed of the machine, as well as dynamic braking.

For the 62IC, the major component of the propelling system is a variable displacement piston pump protected by relief valves.

**Accessories System** The major component of the accessories system is, for the 62E, a belt-driven pump, and for the 62IC, a gear pump. Both of these pumps, protected by a relief valve, send fluid through a control valve to raise and lower hopper, to rotate hopper, and to drive brooms, brushes, and other accessories in their respective machines.

Brooms are driven by hydraulic, high torque, low speed motors.

## **THE VACUUM SYSTEM**

The vacuum system consists of a hydraulically-driven impeller (in the 62IC), and a belt-driven impeller (in the 62E), connected to a damper type hopper vacuum shut-off.

## **Filters and Shakers**

SW/62E models have one fully enclosed, positive sealed, quick-change filter providing 50 sq. ft. (4.65 m<sup>2</sup>) of filtering area and one electric shaker for cleaning the filter. The SW/62IC has one filter providing 92 sq. ft. (8.56 m<sup>2</sup>).

## **HOPPERS**

### **Rotary Trash Relocator™**

The rotary trash relocater (RTR™) on high dump models increases the debris-holding capacity of the hopper, extending the sweeping time before dumping. By rotating the hopper about halfway through the dump rotation, the debris at the lip of the hopper moves to the front wall, leaving the entrance area clear to receive and hold more debris.

## **BRAKES AND TIRES**

### **Brakes**

All models have drum brakes with a hand lever activated mechanical parking brake.

### **Tires**

Front - (62IC) Two 18" pneumatic, solid, or soft shoe. (62E) Two 18" solid, or non-marking solid.  
Rear - (62IC) One 16" pneumatic, solid, or soft shoe. (62E) One 16" solid, or non-marking solid.



## BASIC OPERATING CONTROLS

<b>IGNITION SWITCH</b>	The one position keyswitch is used to turn the machine's power on and off.
<b>STARTER (62IC)</b>	To start gasoline powered machines, turn the key to ON position and press START button. When engine starts, release button. To stop engine, turn key to OFF. To start diesel powered machines, turn key to rear position (counter-clockwise) and hold for 5 to 10 seconds to heat glow plugs. Then, turn key to START position. When engine starts, release switch. To stop engine, turn key to OFF.
<b>HORN</b>	The horn is activated by pressing the horn button located to the left of the driver.
<b>FUEL LEVEL GAUGE (62IC)</b>	The fuel gauge indicates the amount of fuel remaining in the tank.
<b>CHARGE LIGHT</b>	The charge light indicates a discharge of current being used by the sweeper when the alternator is not charging.
<b>HOUR METER</b>	The hour meter records the number of hours the machine has been operated, providing a helpful guide for performing routine maintenance tasks.
<b>ENGINE CHOKE KNOB (62IC)</b>	<p>The choke knob on gasoline-powered machines is connected to a cable which controls the engine choke.</p> <ul style="list-style-type: none"><li>• Pull the knob out for aid in cold-starting the engine.</li><li>• Push the knob in after the engine starts.</li></ul>
<b>ENGINE OIL PRESSURE (62IC)</b>	<p>The engine oil pressure gauge ranges from 0 psi to 60 psi. A reading below 6 psi indicates problems which may result in damage to the engine.</p>
<b>ENGINE TEMP. LIGHT (62IC)</b>	The engine coolant temperature light is activated when the temperature of engine coolant goes above 230° F. Temperatures above 230° F indicate an overheating engine.
<b>FILTER SHAKER</b>	The filter shaker button activates the filter shaker motor prior to dumping or as needed during normal sweeping.
<b>AUXILIARY POWER (62E)</b>	The auxiliary power switch turns the auxiliary drive motor on/off, and controls the hydraulic pump, main broom, and the impeller.

**THROTTLE (62IC)** The throttle adjusts the engine speed from idle to the operating speed.

- The throttle should be in the IDLE position when starting the engine and immediately before shutdown.
- Full throttle position should be used during operation to ensure proper broom speed and dust control.

**DIRECTIONAL CONTROL PEDAL** The directional control pedal controls the speed and direction of the machine. It is also used for slowing the machine or stopping.

- To propel the machine forward, apply pressure to the front of the pedal, increasing pressure to increase speed.
- To propel the machine backward, apply pressure to the rear of the pedal.
- To slow or stop the machine, move foot pedal into neutral.
- For emergency stops move foot pedal past neutral into opposite position. *(Use for emergency stops only! Constant use of this braking method may result in damage to drive components.)*

**⚠ CAUTION**

**PARKING BRAKE** The hydraulic drum brakes on the two front wheels are operated by pressing on the brake pedal. The parking brake is cable activated. To engage the parking brake pull upward on the hand brake lever located on the left side of the front wall of the operator's compartment.

## SWEEPING CONTROLS

**BROOM CONTROL LEVER**      The broom control lever activates the brooms. ("Side Broom ON" position activates the side broom.)

**NOTE**

**Note:** The main broom and side broom may be lowered independently

**NOTE**

**Note:** The "OFF" position is achieved by placing the broom control lever in the center of the slot. Both broom motors (main & side) are deactivated by taking this action.

**MAIN BROOM HANDLE**      The main broom handle to the immediate left of the driver raises and lowers the main broom. For normal sweeping, position the handle at LOWER on the handle slot.

**NOTE**

- When not sweeping, position and lock handle at RAISE position on the handle slot.

**SIDE BROOM HANDLE**      The side broom handle to the immediate left of the driver raises and lowers the side broom.

- When not sweeping, the side broom should remain in the RAISE position.
- To lower the side broom, position the handle at LOWER in the handle slot.

## DEBRIS HOPPER CONTROLS

### HOPPER FILTER SHAKER BUTTON

This button is used to activate the filter shaker prior to dumping or as needed during sweeping operation. It is located to the left of the driver and beside the horn button.

To shake filter:

1. Bring the machine to a complete stop.
2. For 62E, press the "AUX. POWER" switch to turn the brooms off. For 62IC, place the broom control lever in the OFF position.
3. Press and hold the filter shaker button for 20 to 30 seconds.
4. For 62E, press the "AUX. POWER" switch to turn brooms on and resume sweeping. For 62IC, place the broom control lever in the ON position and resume sweeping.

**▲ CAUTION**

*Do not leave the hopper in RAISE position for an extended period of time.*

### HIGH DUMP MODELS

The two levers directly in front of the RTR™ lights are used to raise the hopper to any height up to 60" (1.52 m) and dump it.

**NOTE**

**Note:** Levers are spring loaded to a center off position.

- To raise the hopper, pull back Lever 1 to the RAISE position and hold until the hopper raises to the proper height for the dumpster or container.
- To empty debris, pull back Lever 2 to the DUMP position to rotate the hopper forward and empty the debris.
- To rotate the hopper back, push Lever 2 forward to the RETURN position until the hopper rotates and stops.
- To lower the hopper, push Lever 1 forward to the LOWER position until the hopper stops.
- For 62E, to turn on vacuum & hydraulics, turn on "AUX. POWER" switch.

### ROTARY TRASH RELOCATOR (RTR™)

Rotary Trash Relocator (RTR™) is standard on high-dump models. Its purpose is to increase the holding capacity of the debris hopper to make dumping the hopper necessary less frequently.

## OPERATING PROCEDURES

### PRE-OPERATION CHECKS

Prior to starting the engine, check the following:

- (62IC) Engine oil level
- (62IC) Engine coolant level
- (62IC) Fuel level
- (62E) Battery condition
- Hydraulic fluid level
- Brakes, steering, and directional controls
- The floor beneath the machine for signs of fluid leaks

Fluid levels should be correct. Brakes, steering, and directional controls should be functioning properly. Hoses, lines, and tanks should be free of damage and leaks.

### STARTING

#### **WARNING**

*Before turning the machine on, seat yourself in the operator's seat and make sure the parking brake is locked.*

1. Make sure the directional control pedal is in neutral position.
2. For 62IC, make sure the throttle is in idle position.
3. **Electric:** Turn ignition key to START position.  
**Gasoline-powered:** Turn ignition key to START position, push button located just below key. When engine starts, release button. If the engine is cold, pull out the choke knob and repeat procedure. When engine is running smoothly, push choke knob in.

#### **NOTE**

**Note:** If the engine fails to start, do not continue cranking for more than ten seconds. Allow the starter motor to cool between attempts.

4. Move the machine forward or backward as follows:
  - **Forward:** Apply pressure to the front of the directional control pedal, increasing pressure to increase speed.
  - **Reverse:** Apply pressure to the rear of the pedal, increasing pressure to increase speed.

**SLOWING AND STOPPING**

1. Allow the directional control pedal to move into neutral. The machine will slow and coast to a stop.

**OPERATING ON GRADES**

1. Always travel slowly.
2. Exercise extreme caution when traveling across or turning on grades.

**SWEEPING**

1. Lower the brooms.
  - Lower the side broom by positioning the side broom handle at LOWER in the handle slot.
  - Lower the main broom by positioning the main broom handle at LOWER on the handle slot.
2. Activate the broom motors.
  - To activate the main broom motor only: On the 62E, press the "AUX. POWER" switch to turn on the vacuum and hydraulics. On the 62IC, push the Hopper Raise/Lower lever to the "BROOMS ON" position. (Be sure that the Side Broom On/Off switch is in the "OFF" position.
  - To activate both main and side broom motors: On the 62E, press the "AUX. POWER" switch to turn on the vacuum & hydraulics. Push the Hopper Raise/Lower lever to the "SIDE BROOM ON" position. On the 62IC, push the Hopper Raise/Lower lever to the "BROOMS ON" position, then activate the Side Broom ON/OFF Switch.
3. Drive the machine over the area to be swept.

**EMPTYING THE HOPPER****High Dump  
Models****NOTE**

1. Drive the machine to the dumping area.
2. Use the directional control pedal to position the machine so that the space between the machine and the container or dumpster is adequate to raise the hopper.  
**Note:** Broom controls must be in OFF positions.
3. For 62E, be sure that "AUX. POWER" switch is on. For 62IC, reduce the engine speed.
4. Pull back Lever 1 to RAISE position and hold until the bottom of the hopper is high enough to clear the top of the container.

**⚠ WARNING**

*Never place your hands or other body parts near the lift arms when the hopper is operating.*

5. Use the directional control pedal to slowly and carefully move the machine forward until the hopper is properly positioned to dump debris into the container.

**⚠ CAUTION**

*It is unsafe to travel an extended distance with the hopper raised. Travel only the distance necessary to position the hopper.*

6. At this point, shake filters for 20 - 30 seconds. Pull back Lever 2 to DUMP position to rotate the hopper forward and empty the debris.
7. After hopper empties, push Lever 2 forward to RETURN position until the hopper rotates and stops.
8. Slowly back machine away from dumpster approximately 5 feet.
9. Push Lever 1 forward to the LOWER position until the hopper stops.

**USING THE  
ROTARY TRASH  
RELOCATOR (RTR™)**

1. Use the directional control pedal to stop the machine on a level surface.
2. (On 62IC) Move the throttle to IDLE position.

**NOTE**

**Note:** As you complete Steps three and four, observe the two red lights labeled 1 and 2 in the upper left corner of the control panel.

- Light 1 illuminates when the hopper reaches the minimum height required to use the RTR feature.
- Light 2 illuminates when the hopper reaches the rotation stop point.

3. Pull back Lever 1 to the RAISE position and hold until Light 1 illuminates, then pull Lever 1 to "HOLD" position.

**⚠ WARNING**

*Make sure no one is in the area under or around the hopper.*

4. Pull back Lever 2 to DUMP position and hold until Light 2 illuminates, then release.

**NOTE**

**Note:** This rotates the hopper, causing debris to move from the rear entrance to the front wall of the hopper. Rotating beyond this point will cause debris to be dumped from the hopper.

5. Push Lever 2 forward to RETURN position until the hopper rotates back and stops.
6. Push Lever 1 forward to the LOWER position until the hopper returns to the normal operating position.



**TRANSPORTING THE MACHINE****Loading**

1. Position the machine on the transport vehicle or trailer and apply the parking brake.
2. Tie the machine down using the tie down holes in the frame in front of both front wheels and in the rear of the frame. (There is a total of 4 tie-down areas.)

**NOTE**

**Note:** Attach the tie downs to the frame only.

**Pushing**

1. Push the machine from the front or rear using bumpers only.
2. On the 62IC, before towing, open the tow valve located on top of the main pump by rotating the valve stem 90°. After towing is complete, return valve stem to its original position.

**ATTENTION!**

*Do not tow or push the machine a distance of more than .5 miles (.80 kilometers) or faster than one mile per hour (1.61 km). Exceeding these restrictions may cause damage to the hydraulic system of the 62IC. If towing will exceed the above restrictions, the rear wheel must be raised or supported by a dolly.*

## INTRODUCTION

Regular maintenance on your sweeper results in better cleaning, faster cleaning, and a prolonged service life for the equipment and components. This section contains the following information to help you give your sweeper the maintenance attention it requires:

- A Planned Maintenance Chart
- Service Instructions for Required Maintenance Tasks

Because it is extremely important to your safety, you will see the following **WARNING** repeated throughout this section:

*Never attempt to perform any service on the equipment or components until the machine is OFF, the parking brake is LOCKED, and the wheels are CHOCKED.*

## PLANNED MAINTENANCE CHART

FREQUENCY (IN HOURS)					SERVICE (BY MAINTENANCE AREA)
DAILY	50	100	200	500	
X		X			<p><b>ENGINE (62IC)</b></p> <p>Pressure wash engine</p> <p><i>For additional maintenance requirements, refer to the engine manual furnished with this manual.</i></p>
X		X	X		<p><b>AIR INTAKE AND EXHAUST SYSTEMS(62IC)</b></p> <p>Empty rubber dust cup of air filter element.</p> <p>Clean air filter. <i>NOTE: Clean more often in dusty conditions.</i></p> <p>Replace air filter.</p>
		X	X		<p><b>ELECTRICAL SYSTEM</b></p> <p>Check electrolyte level in battery cells and fill as needed.</p> <p>Clean battery top.</p>
X	X	X			<p><b>COOLANT SYSTEM (62IC)</b></p> <p>Check coolant level and fill as needed.</p> <p>Inspect radiator fins and clean as needed.</p> <p>Blow out radiator fins.</p>

## PLANNED MAINTENANCE CHART

FREQUENCY (IN HOURS)					SERVICE (BY MAINTENANCE AREA)
DAILY	50	100	200	500	
X					<p><b>HYDRAULIC SYSTEM</b></p> <p>Check hydraulic fluid level and fill as needed.</p> <p>Replace breather cap filter element.</p> <p>Replace hydraulic fluid and filter.</p> <p>Check functioning of directional control pedal and adjust as needed.</p> <p>Clean hydraulic fluid strainer in reservoir.</p> <p>Inspect hydraulic oil cooler fins &amp; clean as needed (if so equipped).</p> <p>Blow out hydraulic oil cooler fins with compressed air (if so equipped).</p> <p><b>SWEEPING COMPONENTS</b></p> <p>Inspect brooms for wear and remove strings and debris from bristles and drive assembly.</p> <p>Inspect broom skirts for wear and adjust or replace as needed.</p> <p>Rotate main broom end-to-end.</p> <p>Perform main broom adjustment test and adjust as needed.</p> <p>Inspect the side broom for wear and adjust as needed.</p> <p><i>Replace main and side brooms as needed.</i></p> <p style="padding-left: 40px;"><i>Main Broom - Bristles are 1" in length.</i></p> <p style="padding-left: 40px;"><i>Side Broom - Bristles are 3" in length.</i></p>
				X	
				X	
X				X	
	X				
		X			
X					
	X				
	X				
	X				
X					

## PLANNED MAINTENANCE CHART

FREQUENCY (IN HOURS)					SERVICE (BY MAINTENANCE AREA)
DAILY	50	100	200	500	
X					<p><b>HOPPER</b></p> <p>Check hopper filter and clean or replace as needed.</p>
	X				<p>Check hopper clearance from floor and adjust as needed.</p>
X					<p>Inspect the hopper flaps for wear or damage and replace as needed.</p>
		X			<p>Inspect hopper side and frame seals for wear or damage. Adjust or replace as needed.</p>
				X	<p>(on 62IC) Lubricate the pillow blocks supporting the dump mechanism.</p>
					<p><b>STEERING</b></p>
				X	<p>Lubricate steering linkage rod ends.</p>
				X	<p>Lubricate steering fork assembly.</p>
	X				<p>Check for leaks.</p>
					<p><b>PARKING BRAKE</b></p>
			X		<p>Check for proper functioning and adjust as needed.</p>

## PLANNED MAINTENANCE CHART

FREQUENCY (IN HOURS)					SERVICE (BY MAINTENANCE AREA)
DAILY	50	100	200	500	
X			X		<p><b>TIRES</b></p> <p>Visually inspect for wear and damage. Repair or replace as needed.</p> <p>Check pneumatic tires for proper air pressure (90 psi).</p>
				X	<p><b>MISCELLANEOUS</b></p> <p>Inspect latches and hinges. Tighten and lubricate as needed.</p>
			X		<p>Check anti-static drag chain on rear wall of broom chamber for damage or excessive wear. Replace as needed.</p>
				X	<p>Check side broom lift cable, and brake cable for wear.</p>
			X		<p>Check lugnuts for proper torque.</p>
X					<p><b>IMPELLER (62IC)</b></p> <p>Check for hydraulic fluid leaks.</p>

## ENGINE (62IC)

---

Maintenance requirements and service instructions for your sweeper engine are outlined in the following parts of this Maintenance section:

- Air Intake and Exhaust Systems
- Electrical System
- Fuel System
- Coolant System
- Lubrication System

All basic maintenance tasks are listed with their recommended frequencies on the Planned Maintenance Chart in this manual. Important additional maintenance requirements and instructions are explained in the engine manual which comes with your machine.

---

 **WARNING**

*Never attempt to perform any service on the equipment or components until the engine is OFF, the parking brake is LOCKED, and the wheels are CHOCKED.*

## **AIR INTAKE AND EXHAUST SYSTEMS (62IC) SERVICE INSTRUCTIONS**

### **AIR FILTER REMOVAL**

1. Turn off the engine and set the parking brake.
2. Lift the engine cover.
3. Locate the air filter and unlatch the ring clamp.
4. Remove the dust cup.
5. Pull the rubber plug out of the dust cup and empty the contents.
6. Unscrew the wingnut.
7. Pull the air filter out of its housing.

### **AIR FILTER CLEANING**

1. Once you have removed the air filter, empty the dust cup and clean the interior of the air filter housing.
2. Use an air hose to blow out the air filter. Air pressure should be 100 psi or less.

### **AIR FILTER INSPECTION**

1. After you clean the air filter, check it for holes by passing a light bulb inside it.

### **AIR FILTER INSTALLATION**

1. Wipe out the air cleaner housing with a damp cloth. Be sure all dirt is removed.
2. Install the cleaned replacement filter so that the fins are at the far end of the housing. Be careful not to damage the fins.
3. Replace the wing nut and tighten it.
4. Replace the rubber plug in the dust cup.
5. Replace dust cup, being sure embossed word "top" on cup is positioned correctly (up).
6. Tighten the ring clamp.
7. Check the condition of intake hoses and clamps.
8. Close the engine cover.



# ELECTRICAL SCHEMATIC

## SW/62E

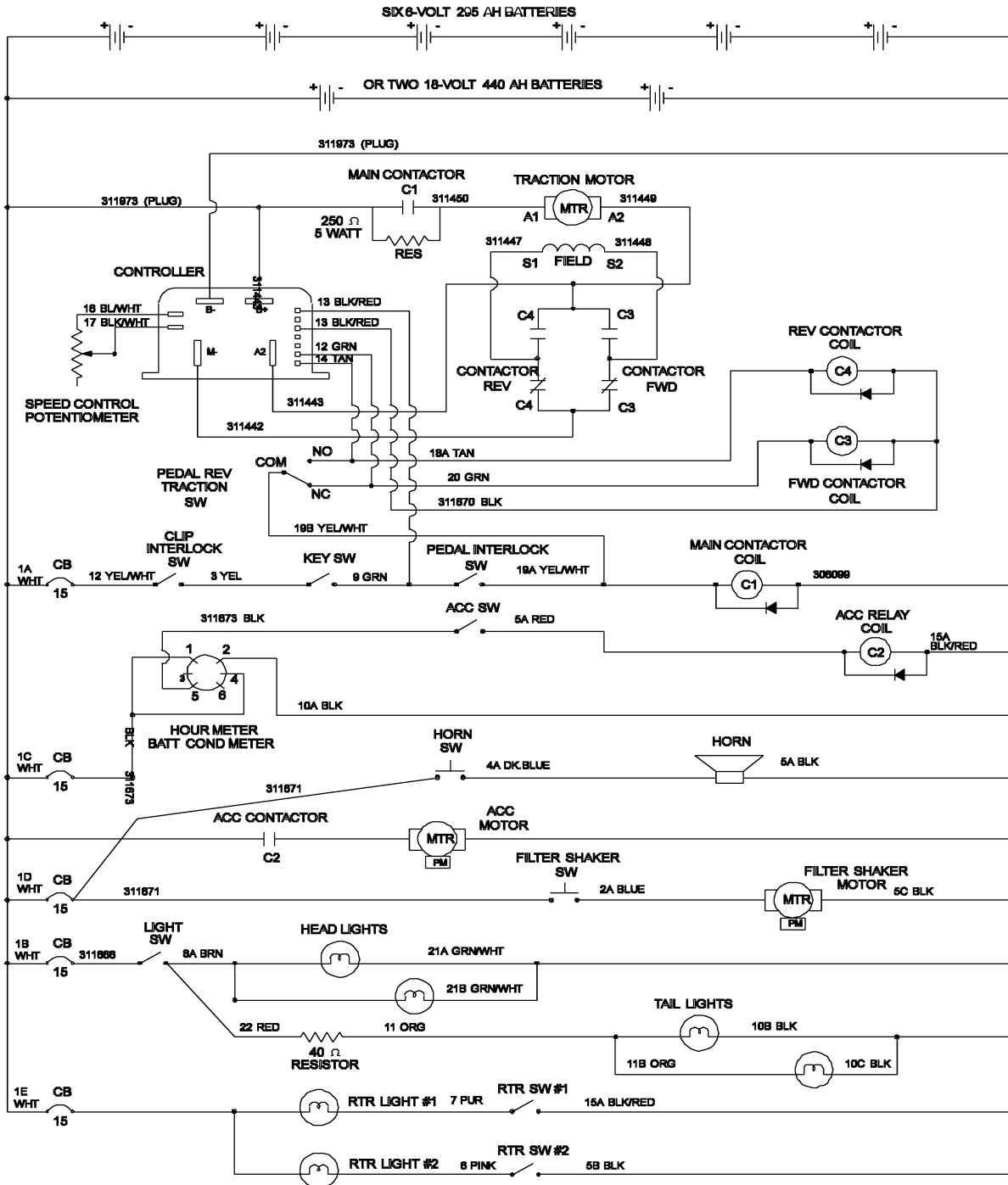

ELECTRICAL SCHEMATIC SW-62E

# ELECTRICAL SCHEMATIC

## SW/62IC

### - GASOLINE & LP GAS - KUBOTA WG-750 GASOLINE

SW-62 GAS  
ELECTRICAL SCHEMATIC

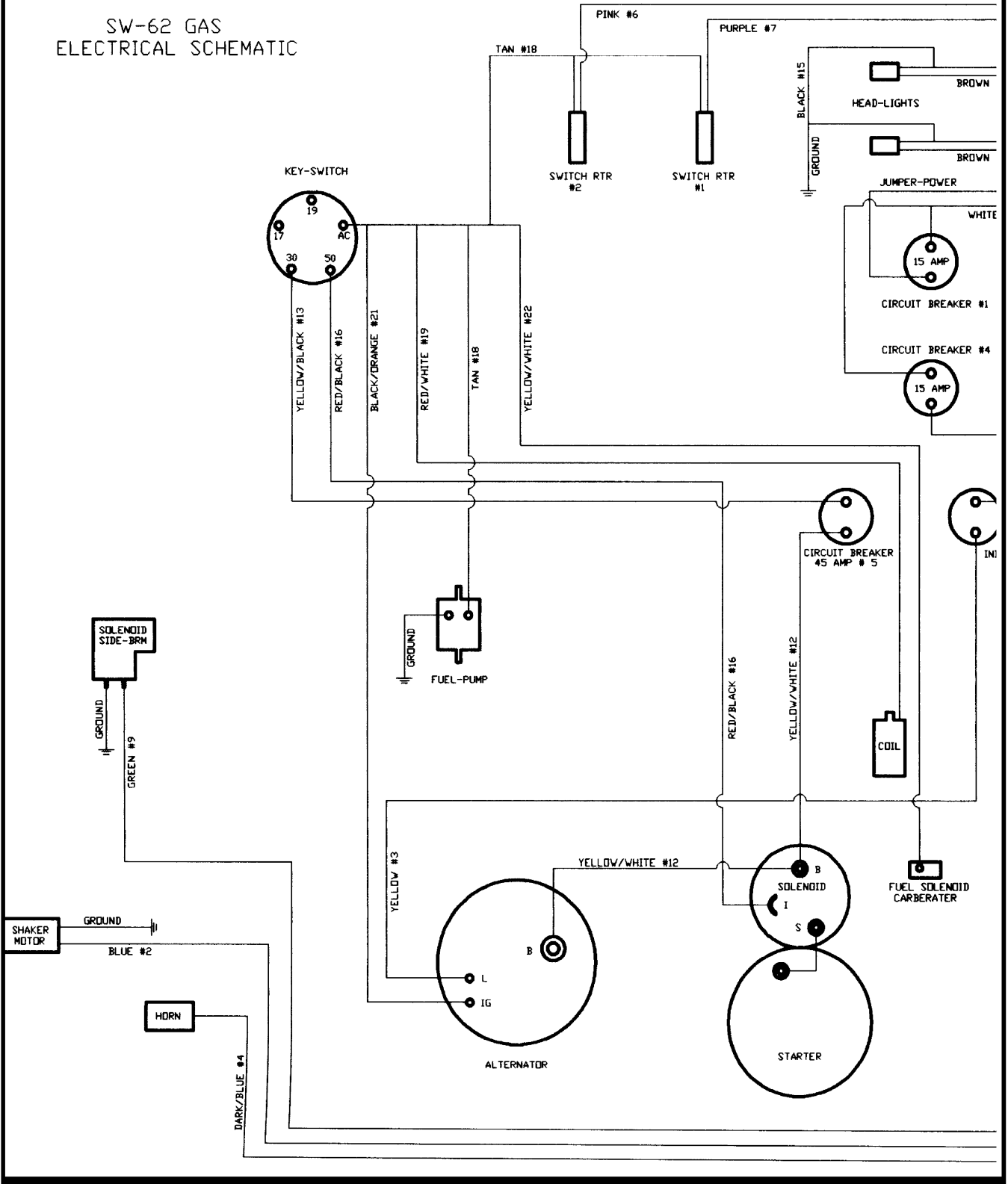

# ELECTRICAL SCHEMATIC

## SW/62IC (Cont.)

- GASOLINE & LP GAS - KUBOTA WG-750 GASOLINE-

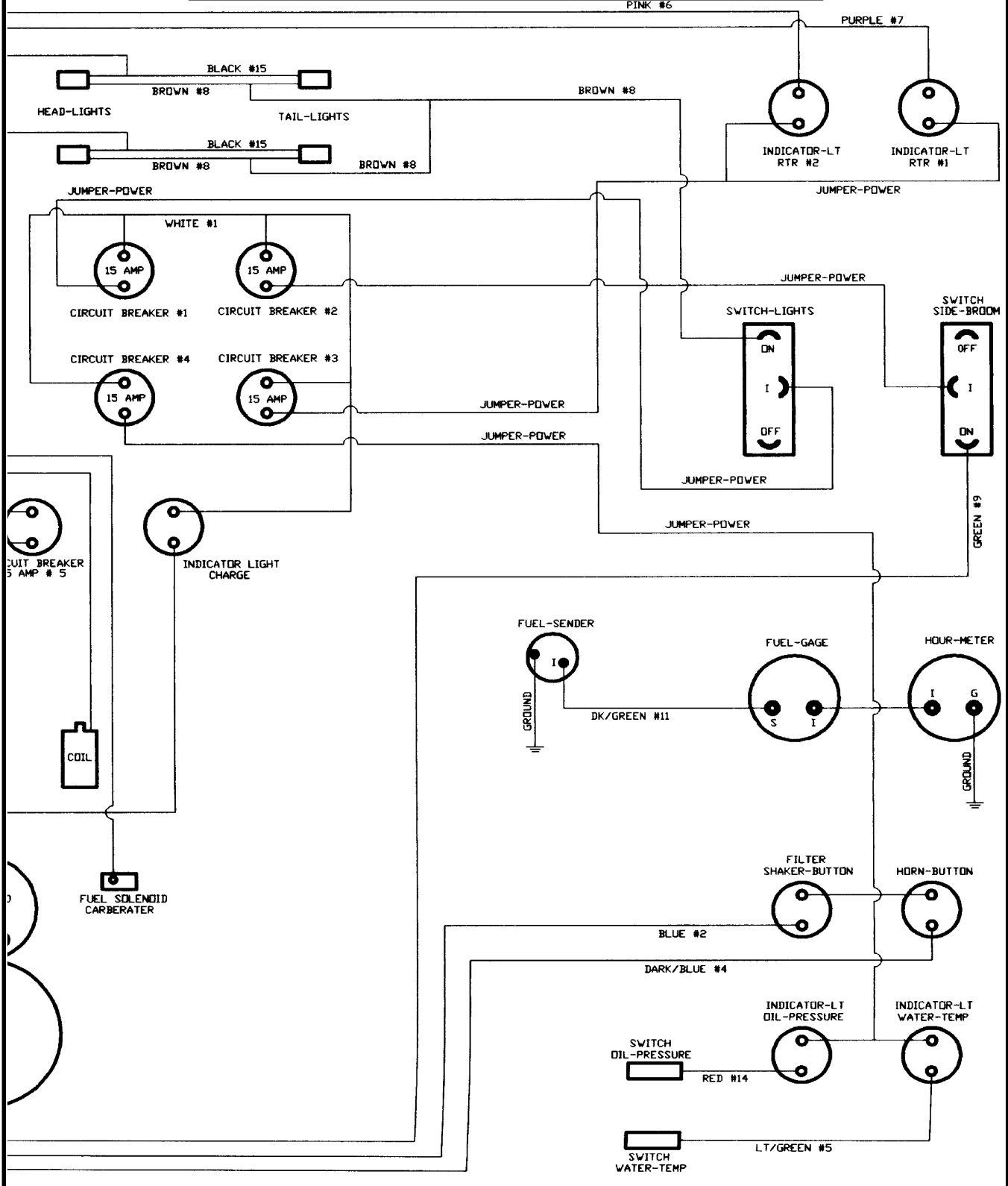

# ELECTRICAL SCHEMATIC

## SW/62IC

### - LPG - KUBOTA WG-750 LIQUID PROPANE

SW-62 LP  
ELECTRICAL SCHEMATIC

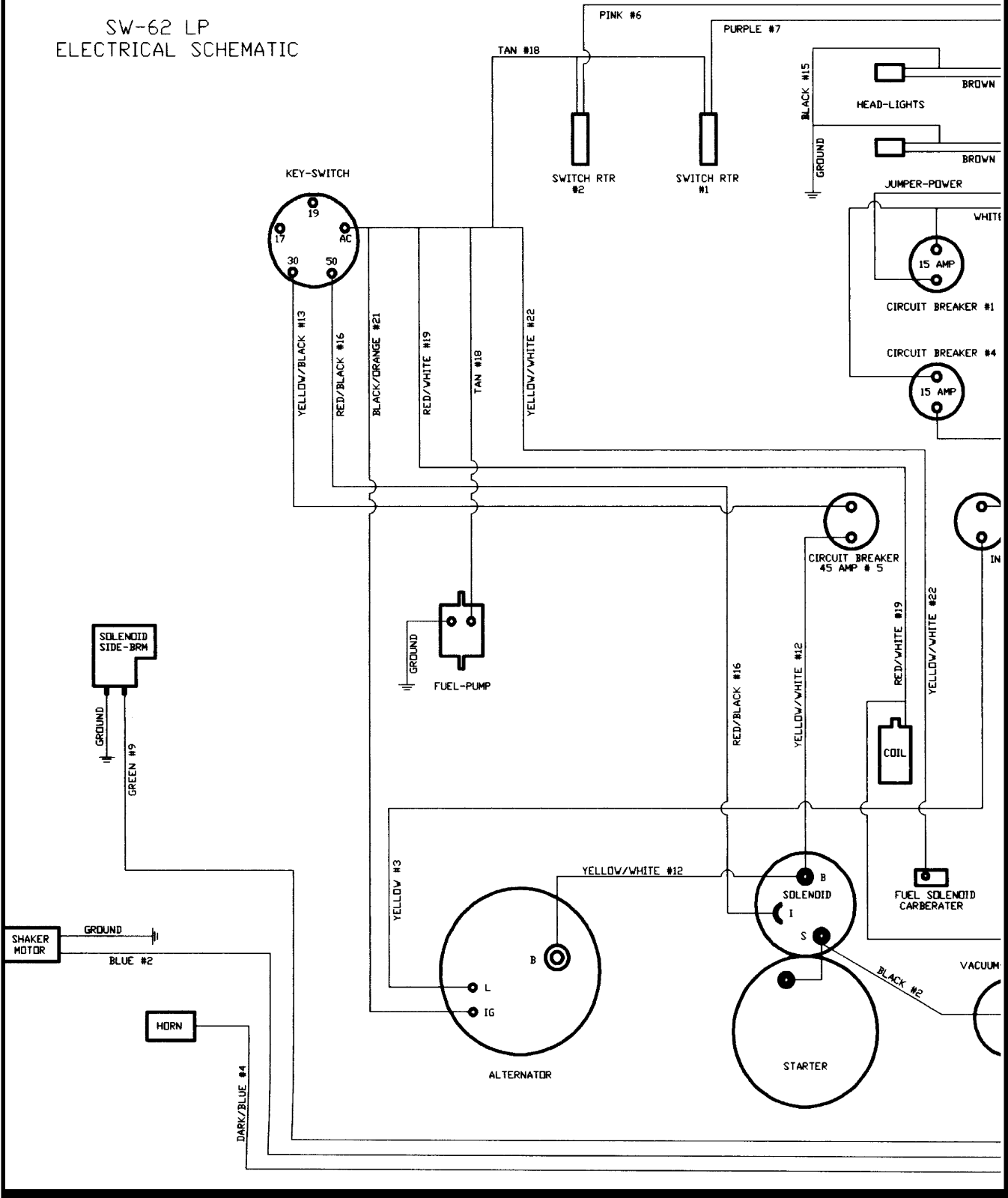

# ELECTRICAL SCHEMATIC

## SW/62IC (Cont.) - LPG - KUBOTA WG-750 LIQUID PROPANE

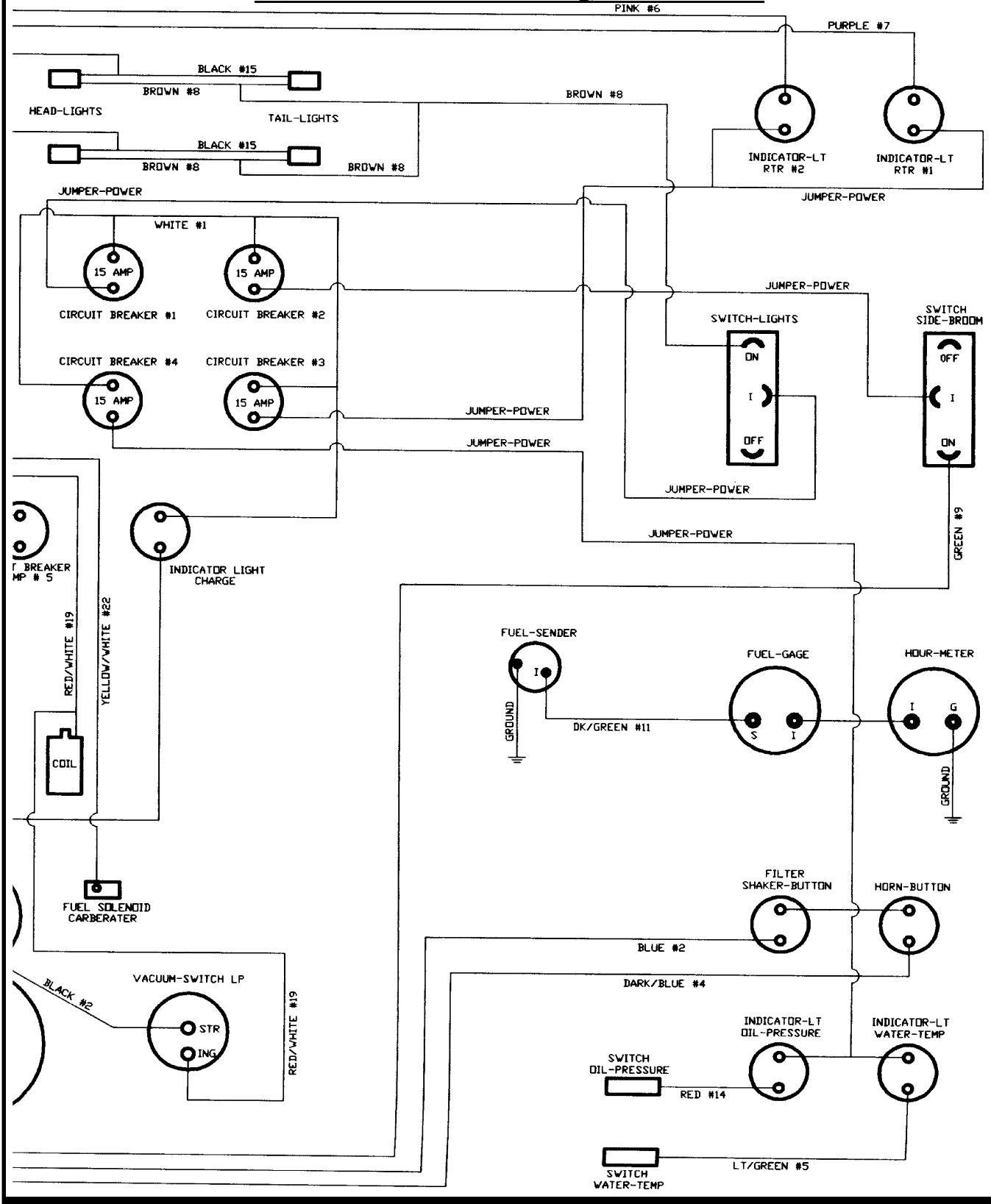

# ELECTRICAL SCHEMATIC

## SW/62IC

### - DIESEL - KUBOTA D-722 DIESEL

SW-62 DIESEL  
ELECTRICAL SCHEMATIC

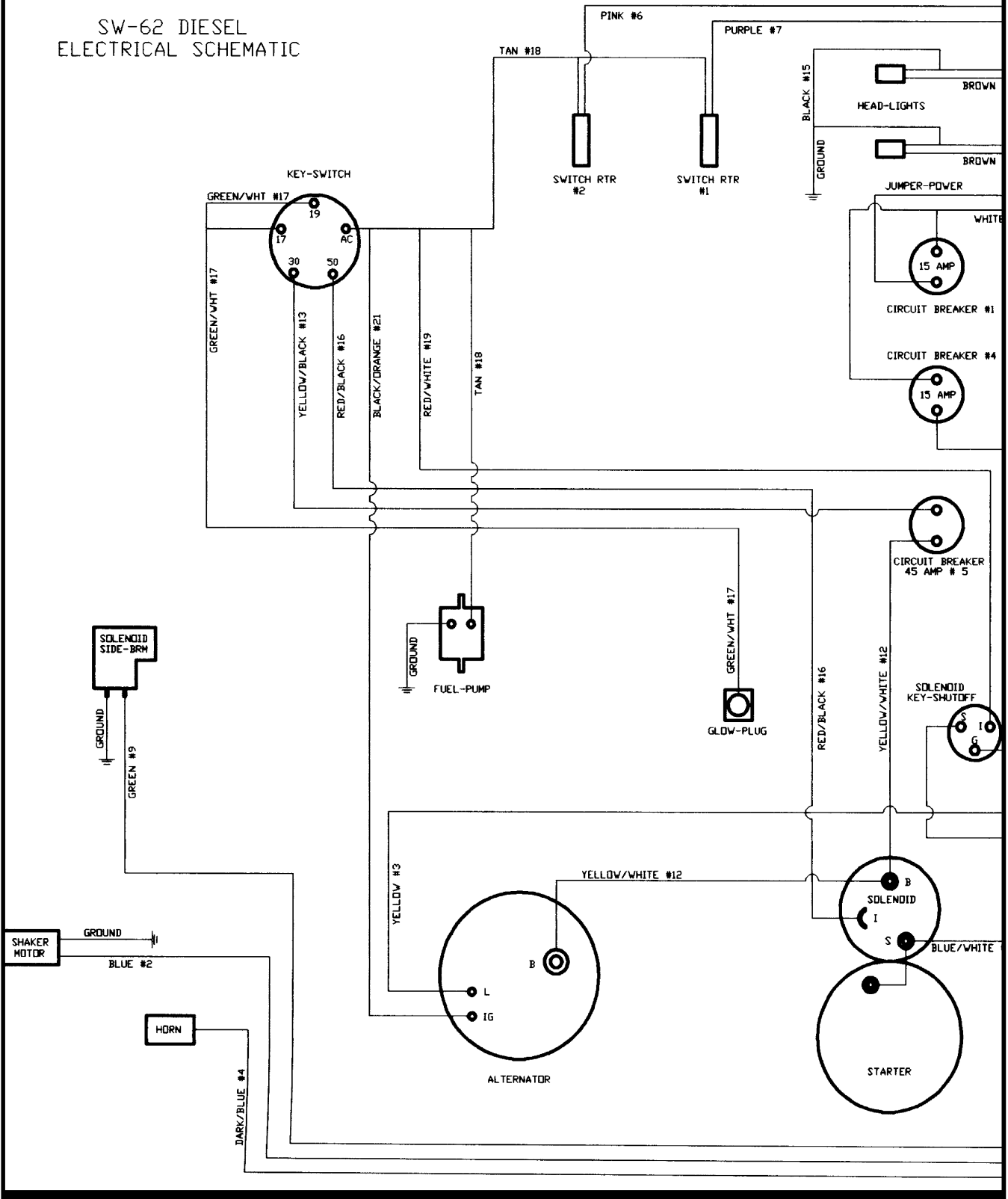

# ELECTRICAL SCHEMATIC

## SW/62IC (Cont.)

### - DIESEL - KUBOTA D-722 DIESEL

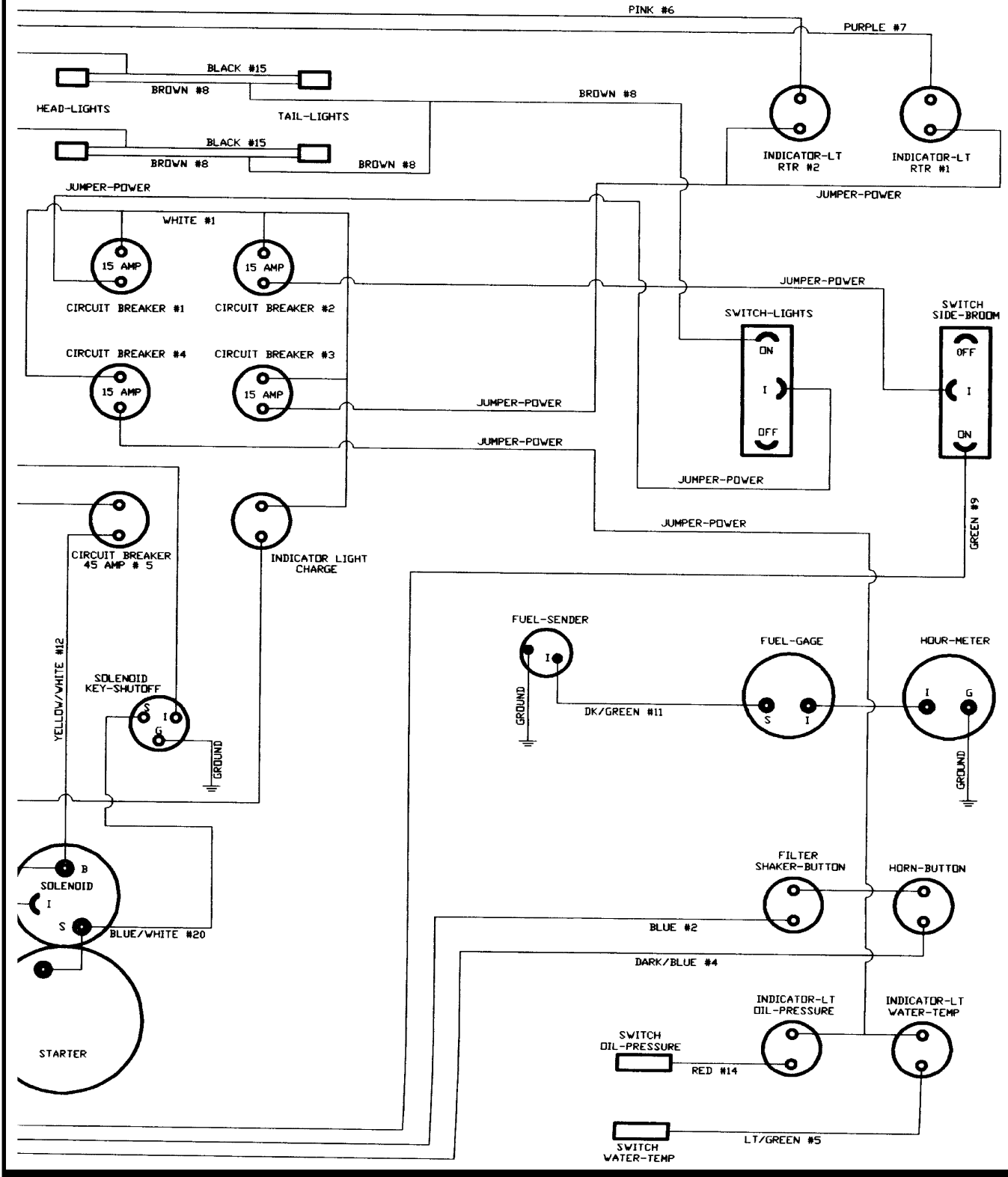

## **ELECTRICAL SYSTEMS**

### **SERVICE INSTRUCTIONS**

#### **BATTERY CLEANING**

1. Combine baking soda and water in a strong solution.
2. Brush the solution over the battery top, including terminals and cable clamps. Make sure the solution does not enter the battery.
3. Using a wire brush, clean the terminal posts and cable clamps.
4. Apply a thin coating of vaseline to the terminals and cable clamps.

#### **BATTERY REPLACEMENT (62IC)**

*Remove the negative battery cable before you remove the positive battery cable. This is done to prevent accidental electrical shorting which can result in personal injury.*

1. Disconnect the negative (-) cable and then the positive (+) cable.
2. Remove the battery.
3. Install new battery.
4. Connect the positive (+) battery cable first, then the negative (-) cable.

#### **CIRCUIT BREAKERS**

If a circuit breaker trips, it can be reset by pressing the reset button in the center of the breaker. (The circuit breakers are located on the rear cover to the left of the driver.)



## FUEL SYSTEM (62IC)

### WARNING

1. Never attempt to perform any service on the equipment or components until the engine is OFF, the parking brake is LOCKED, and the wheels are CHOCKED.
2. Never operate an LPG powered sweeper when any component in the fuel system is malfunctioning or leaking.
3. Never bypass safety components unless you are testing them.
4. Replace any defective safety components before operating the sweeper.
5. During repair or servicing of the fuel system, work in a properly ventilated area and do not smoke or allow an open flame near the fuel system.
6. When disconnecting the tank coupling, always wear gloves. LPG fuel can freeze bare hands.
7. Under no circumstances should the fuel filter lock be bypassed, except when testing. After testing, always reconnect lock. Bypassing the fuel filter lock after testing creates a potential fire hazard.

### CHECKING THE LPG FUEL FILTER LOCK

1. Start the engine. Then remove the vacuum hose going to the fuel filter lock. The solenoid should close, shutting off the fuel supply and stopping the engine.
  - If the engine continues to operate, the fuel filter lock should be replaced.
  - If the engine stops, the fuel filter lock is operating properly.
2. With the engine stopped, let the machine stand while the LPG tank valve is open (the hose is removed from the fuel filter lock). After 10 minutes, try the starter motor.
  - If the engine starts or fires, this indicates a fuel leak has occurred. Replace the fuel filter lock immediately.
  - If the engine simply turns over, this indicates the fuel filter lock is operating correctly.

## **COOLANT SYSTEM (62IC) SERVICE INSTRUCTIONS**

### **BLOWING OUT RADIATOR FINS**

**NOTE: Make sure radiator is cool before blowing out the radiator fins with compressed air.**

### **REVERSE FLOW FLUSHING**

1. At the engine, disconnect the hoses.
2. Make sure the radiator cap is on tight.
3. Using a hose clamp, clamp a flushing gun onto the lower hose.
4. Turn on the water and fill the radiator.
5. To keep from damaging the radiator, apply air pressure slowly and carefully.
6. Shut off the air pressure, refill the radiator with water, and reapply the air pressure. You will need to repeat these steps until water flushed from the radiator runs out clear.
7. Inspect and clean the radiator cap.
8. Inspect and reconnect the hoses.
9. Refill the radiator with coolant.

**NOTE: Use a 50/50 mixture of water and an anti-freeze with an ethylene glycol base.**

## LUBRICATION

**Gasoline and LPG Engines:** Use any SF or SG rated oil meeting API specifications and suited to seasonal temperatures.

Refer to the Engine Manufacturer's Operator Manual for these specifications.

### CHANGING ENGINE OIL (62IC)

1. Place a drain pan under the engine on the floor.
2. Remove the drain plug and allow oil to drain into the pan (Gasoline or LPG engines will drain from front of oil pan. Diesel engines will drain from bottom of oil pan.)
3. Remove the used oil filter and replace with a new one.
4. Dispose of oil and oil filter in an approved manner.
5. Remove the engine oil cap, add oil in the amounts listed in engine manual, then secure the cap.

## LUBRICATION POINTS

Lubrication	Type of Lubrication	Frequency (In Hours)
Steering Cylinder (2 fittings)	Grease	500
Steering Fork Assembly	Grease	500
Hood Latches & Hinges	Oil	500

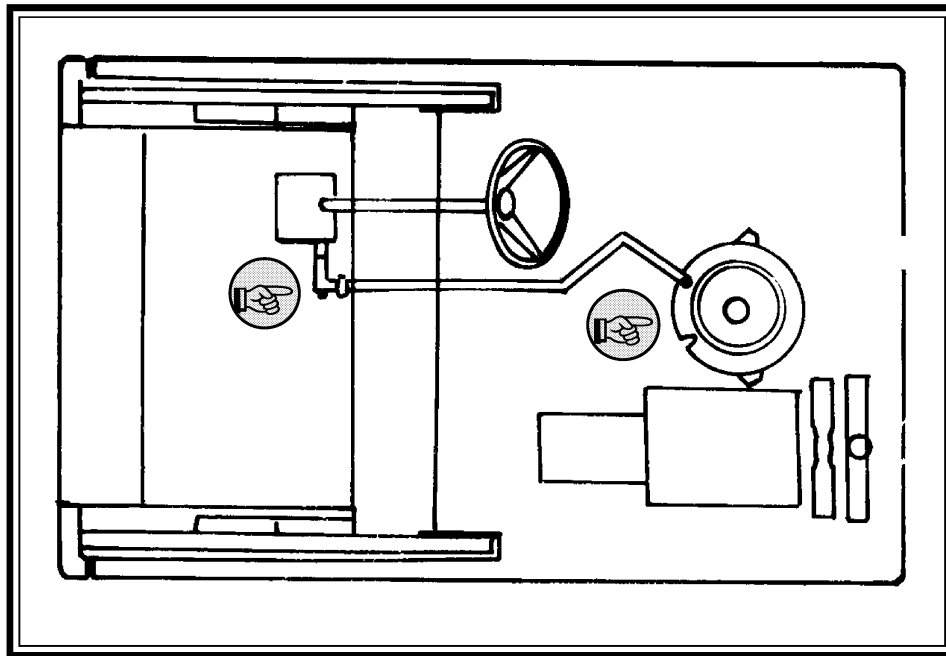

**Steering Lubrication Points**

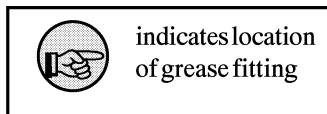

## HYDRAULICS SYSTEM SERVICE INSTRUCTIONS

### FILLING THE FLUID RESERVOIR

**NOTE:** The reservoir is located inside the machine and is accessible by tilting the rear cover or clip backward.

1. When the machine is cool and the hopper is in the lowered position, remove the dipstick. Fluid level should be between the high and low marks on dipstick.

**NOTE: DO NOT OVERFILL! DO NOT USE TRANSMISSION FLUID INSTEAD OF HYDRAULIC FLUID. AAR PowerBoss recommends Chevron Dello 400.**

2. If the fluid level is not acceptable, add hydraulic fluid.

### HYDRAULIC FLUID VISCOSITY SPECIFICATIONS

---

SUS @ 100° F 510-560

SUS @ 210° F 78-84

### CHANGING THE HYDRAULIC FLUID (62IC)

1. Turn off the machine and engage the parking brake.
2. Place a drain pan on the floor below the reservoir.
3. Remove the drain plug located on the bottom rear of the reservoir and allow the fluid to drain.
4. Discard the fluid, then replace and retighten the drain plug.
5. Remove the filler/breather cap located on top of the reservoir and fill the reservoir with approved hydraulic fluid.

**NOTE: Five (5) gallons (US) of fluid required.**

6. Check the dipstick to ensure the proper two-thirds level is achieved.
7. Install a new filler/breather cap assembly.
8. Check the drain plug for leakage.

### **CHANGING THE HYDRAULIC FLUID FILTER**

1. Turn off the machine and engage the parking brake.
2. Unscrew the oil filter cartridge from the mount and discard.
3. Apply a thin coating of fluid to the seal of a new filter element.
4. Thread onto the mount and hand tighten.
5. Tighten an additional one-half turn beyond hand tight.

**NOTE: Do not overtighten.**

6. Start the machine, shut it off, then check for leakage.

### **ADJUSTING THE DIRECTIONAL CONTROL RETURN SPRING (62IC)**

You may encounter "creeping" problems from time to time. Creeping means the machine moves backward or forward when the forward/reverse pedal is in neutral. A grinding noise when the engine is shut down is also an indicator that the directional control return spring needs adjusting. If this occurs, perform the procedure which follows:

1. Turn off the engine, engage the parking brake, and chock both wheels.
2. Jack the rear of the machine so that the rear tire just clears the floor. Use two jack stands to support the machine. **DO NOT USE A JACK ALONE TO HOLD THE MACHINE !!**
3. Locate the forward/reverse adjustment bracket mounted beneath the pump on the pump mounting plate.
4. Slightly loosen the bolt on the center of the bracket.
5. Now loosen the locking nut on each of the adjusting bolts on the side of the bracket closest to the pump mounting plate.
6. From the operator's seat, start the engine and run at half throttle.
7. Turn the adjusting bolts while watching the rear wheel. Continue to adjust until the rear wheel does not turn in either direction.

8. Fully open throttle. Push the directional control pedal forward and backward to be sure pump stays in neutral. Check wheel again and adjust as needed until the wheel remains motionless.
9. Retighten all the locking nuts and the bolts.
10. Turn the engine off and lower the machine to the floor.

# HYDRAULIC SCHEMATIC SW/62E

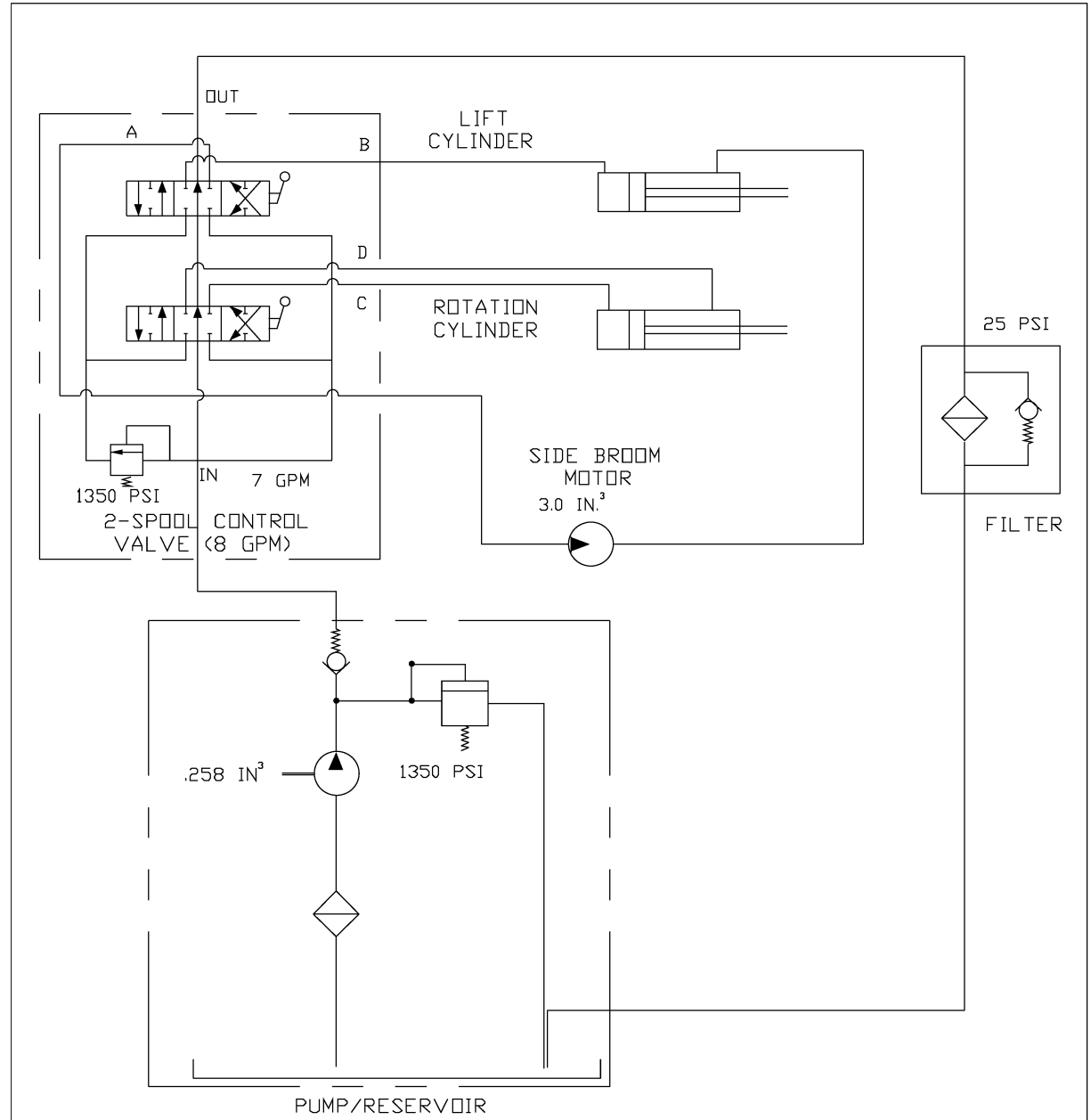

PowerBoss™ SW/62 ELECTRIC  
HYDRAULIC SCHEMATIC



## HYDRAULIC SCHEMATIC SW/62IC

2-SPOOL CONTROL VALVE (8 GPM)

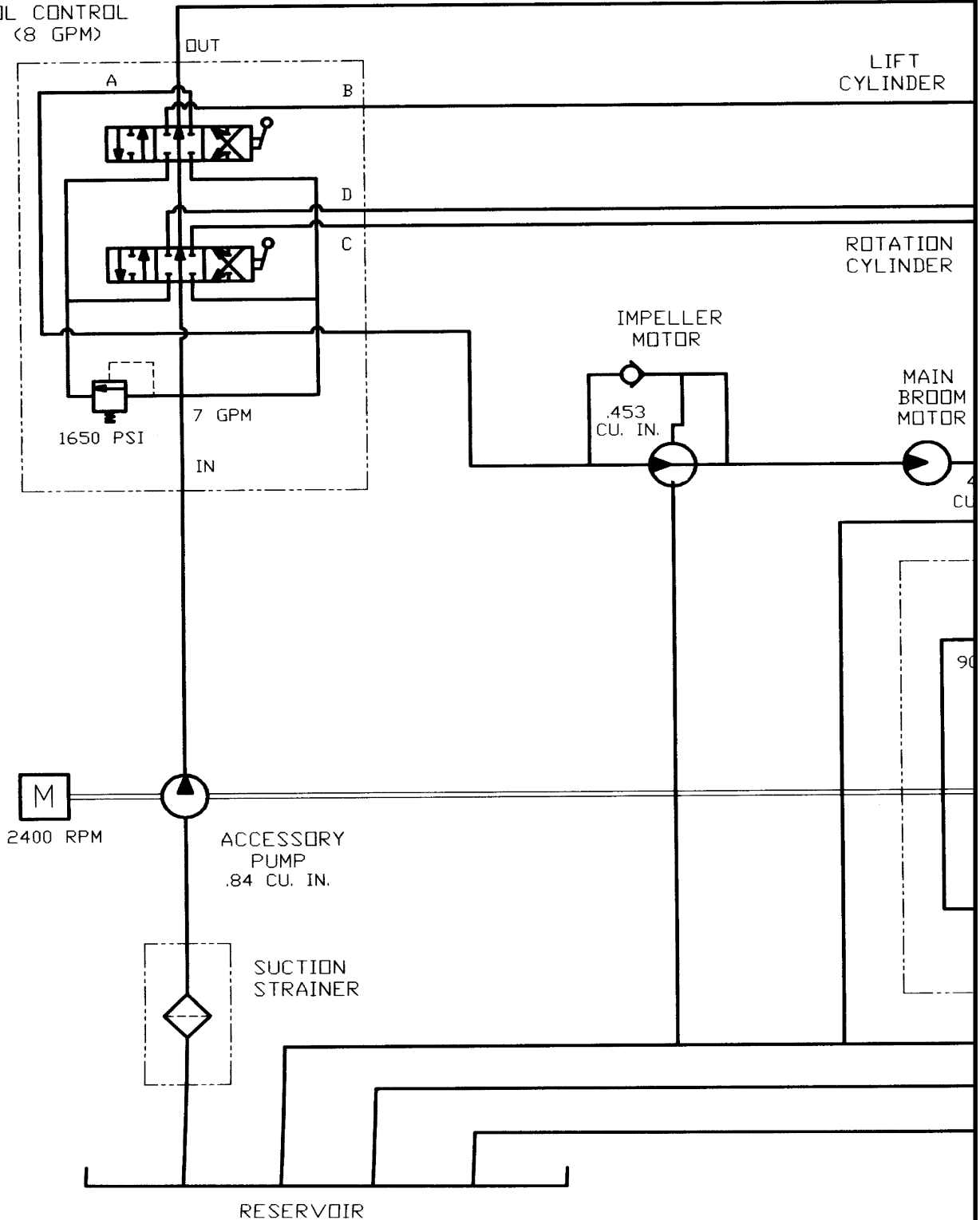

# HYDRAULIC SCHEMATIC SW/62IC

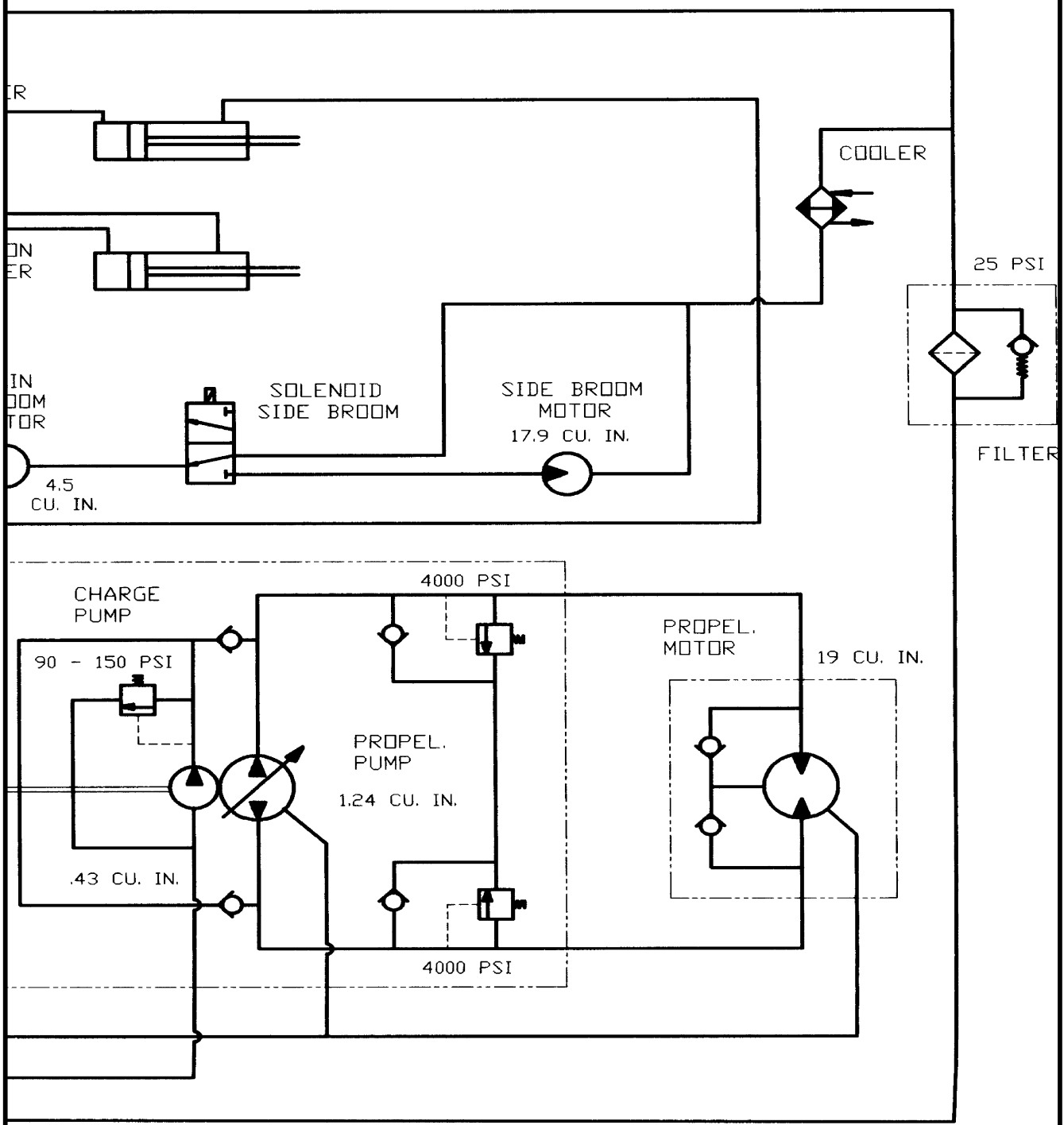

*PowerBoss™* SW/62 GAS/DSL/LPG  
HYDRAULIC SCHEMATIC

## SWEEP COMPONENTS SERVICE INSTRUCTIONS

### BROOM DOOR FLAP INSPECTION

*NOTE: Perform this inspection when the machine is parked on a level surface.*

1. Turn the machine off and lock the parking brake.
2. Inspect broom door (side panel) flaps for wear and damage. Flap clearance should be 1/8" (3.18 mm) above the floor.
3. Worn and damaged flaps should be replaced immediately to maintain proper dust control.

### BROOM DOOR FLAP REPLACEMENT AND ADJUSTMENT

The flaps are attached to the side panels by a retainer bar and hex bolts and nuts. To remove the flaps, remove nuts, bolts, and retainer bar. To adjust flaps, loosen nuts and bolts slide flap up or down as needed. Retighten nuts and bolts.

### MAIN BROOM ADJUSTMENT TEST

*NOTE: Perform this adjustment on a flat, smooth test surface.*

1. Drive the machine onto the test surface with the main broom in the RAISE position.
2. Set the parking brake and position the main broom handle in LOWER position.
3. Push the broom control lever to BROOMS ON position to activate the broom motor and open throttle to full RPM.
4. Allow about 45 seconds for the broom to operate, then deactivate the broom motor and raise the broom.

*NOTE: Test time will vary according to the test surface used.*

5. Drive the machine clear of the test site.
6. Examine the polished pattern made by the broom on the test area.

**NOTE:** A rectangular shape the length of the main broom, for the 62E, 1" (2.54 cm) wide, or 2" (5.08 cm) wide for the 62IC, indicates the main broom is properly adjusted. A pattern smaller than 1" (2.54 cm) or 2" (5.08 cm) indicates need for lower adjustment. A pattern wider than 1" (2.54 cm) or 2" (5.08 cm) indicates a need for higher adjustment. If pattern is tapered from end to end instead of rectangular, see Taper Adjustment on the next page.

### Main Broom Test Pattern

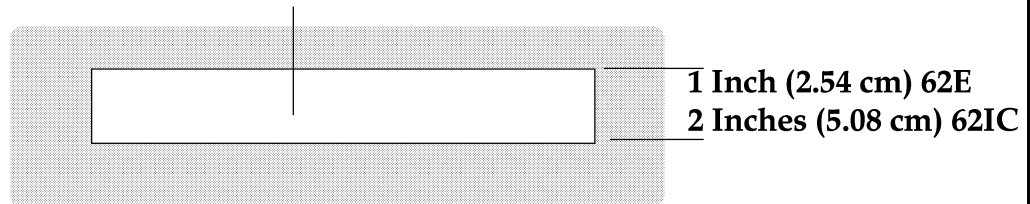

### MAIN BROOM HEIGHT ADJUSTMENT

1. Turn the machine off and lock the parking brake.
2. Position the main broom lever in the LOWER position.

**NOTE:** The adjustment knob is located in the operator's compartment in front of driver's left knee.

3. Turn the broom adjusting knob clockwise one-eighth turn to free locknut.
4. Turn the locknut counter-clockwise to allow space for adjustment.
5. Make a lower or higher adjustment with the knob as required.
6. Retighten the locknut.
7. Repeat the main broom adjustment test to see that the broom is properly adjusted.

## MAIN BROOM TAPER ADJUSTMENT

**NOTE** It is not usually necessary to perform this adjustment. However, if the main broom adjustment test shows a pattern that is tapered in length (one end is wider than the other), perform the procedures which follow.

### Correct Taper Pattern



### Incorrect Taper Pattern

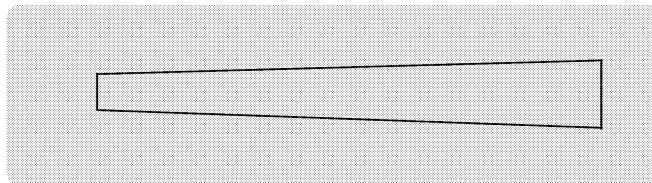

### Main Broom Taper Patterns

1. Locate the adjusting screws directly beneath the floor pan.
2. Loosen the retaining bolts on the outside of the mounting bracket.
3. Raise or lower the right end of the main broom. (The left end of the broom remains fixed. All adjustments affect the right end of the broom.)
4. After adjustment, tighten retainer bolts.
5. Repeat the main broom adjustment test to see that the broom is properly adjusted.

**SIDE BROOM ANGLE ADJUSTMENT**

The angle adjustment is controlled with a stop bolt. This stop bolt is located at the top front of the side broom arm (under the spring). To increase the angle of the side broom, loosen jam nut and turn stop bolt counter-clockwise. Be sure to retighten the jam nut back down once the adjustment is made.

**SIDE BROOM HEIGHT (WEAR) ADJUSTMENT**

The height of the side broom is adjusted with the use of a stop bolt located at the lower rear of the curb broom arm. As the side broom wears it will be necessary to lower the arm. To lower the side broom, loosen the jam nut on stop bolt. Turn the stop bolt in a counter-clockwise direction, check side broom for proper contact and re-tighten the jam nut.

**SIDE BROOM LIFT CABLE ADJUSTMENT**

This adjustment is made at the cable clevis attached to the side broom assembly. It controls the height of the side broom in the RAISED position. This adjustment must be made with the hopper fully lowered.

1. Pull the side broom lever into the RAISED position.
2. Loosen the locknut on the threaded rod at the clevis.
3. Turn the threaded rod in or out to set the side broom in the maximum raised position.
4. Secure the cable adjustment by tightening the locknut.

**MAIN BROOM REPLACEMENT (Bristles worn to length of 1 inch ; 2.54 cm)**

1. Turn the machine off and lock the parking brake.
2. Push the main broom control lever to the LOWER position.
3. Remove the right side panel (on side with driver's seat). (This involves removing three bolts.)
4. Using a 3/4" wrench, remove the hex bolt on the main broom idler mount.
5. Pull the main broom idler mount straight out to remove.
6. Grasp the main broom by the plastic drive hub, pull the main broom straight out and clear of the broom chamber.
7. Depending on broom condition, you can either rotate the old broom end-to-end and re-install it or you can install a new broom. Slide the main broom into the broom chamber and align the broom with the metal drive hub located at the far side of the broom chamber.

If a worn broom is being replaced, install the new broom by first adjusting the broom arms up, to better match the position of the drive hub with the hub on the new broom.

8. Once the broom is started onto the drive hubs, rotate the broom counter-clockwise while pushing lightly against the broom.
9. Once the broom is fully engaged, replace the idler hub while aligning the seats in the idler hub with the broom's drive hub ears.
10. Install the retaining bolt into position and tighten with the wrench.
11. Re-install the right side panel.
12. Perform a main broom adjustment test and adjust as needed.

**SIDE BROOM REPLACEMENT (Bristles worn to length of 3 inches ; 7.62 cm)**

*NOTE: The side broom features a quick release mechanism which enables the operator to remove the brush in seconds.*

1. Raise the side broom and lock in RAISE position.
2. Turn the side broom by hand until the brush retainer bar is accessible.
3. Lift the bar and turn the broom clockwise (about one eighth of a turn) until the lock pins in the broom disengage from the drive plate.
4. Install the new broom by positioning the three drive pins into the pilot holes of the drive plate.
5. Lift and rotate the broom until the broom retainer bar springs into the locked position.
6. Check to make sure all three drive pins are properly engaged.



## **HOPPERS**

### **SERVICE INSTRUCTIONS**

#### **HIGH DUMP HOPPER REMOVAL AND REPLACEMENT**

It is not usually necessary to remove or replace the hopper on high dump models. However, if it becomes necessary for maintenance or to install an option, use the following procedure to remove:

1. Park the machine on a level surface and engage the parking brake.
2. Raise the hopper and position the high dump hopper dolly, a platform truck or similar four wheeled cart under the hopper.
3. Set the hopper down on the truck and turn the engine off.
4. Cycle the rotation control handle (#2) in both positions to relieve any residual hydraulic pressure.
5. Remove three bolts, washers, nuts, and backing plate.
6. Disconnect the wire connections at the right side of the hopper.
7. While spreading dump arms slightly, roll the hopper away from the machine.

**TO REPLACE:**

1. Position the hopper on the dolly so as to align the mounting holes in the sides of the hopper with the rotation mounts on the arms. Lift arms should be positioned about 1/3 of way up.
2. Engage lift arm rotation plates with three mounting bolts on each side of the hopper.
3. Start the machine and lift hopper.
4. Drive the truck away from the hopper dolly or cart.
5. Lower hopper.
6. Engage wire connections at right side of hopper.

**FILTER REMOVAL:**

1. Release the latch on the hopper cover and raise cover.
2. Disconnect the wire harness leading to the filter shaker motor.
3. Unscrew the two screws (each attached using one conical washer and an isolator) securing the filter retainer bars to the hopper.
4. Remove the shaker motor assembly and filter retainer bars.
5. Lift out the panel filter.

**FILTER CLEANING**

The dust control filter is a permanent type paper element filter. It may be vacuumed, blown out with compressed air, tapped against the floor, or washed with soap and water.

1. If blown out with compressed air, use 100 psi or less.
2. If washed with soap and water, use 40 psi water pressure or less.

**NOTE:** *Make sure the filter is thoroughly dried while standing on its side before installing in the hopper. Do not install or use a wet filter.*

**FILTER REPLACEMENT**

1. Insert the panel filter.
2. Install the shaker motor assembly.
3. Install and tighten the four filter retaining screws & isolators.
4. Hook the wire harness to the filter shaker motor.
5. Close the hopper cover and secure the latch.

## HOPPER FLOOR CLEARANCE & DUMP ADJUSTMENTS

In order to perform properly, the hopper must maintain a distance of 3-1/2" (8.89 cm) from the floor to the rear hopper entrance lip. The front of the hopper should be adjusted so that the front bumper aligns with the hopper frame where the two meet. When properly adjusted, the front edge of the hopper will be 5" (12.7 cm) to 6" (15.24 cm) from the floor.

### ADJUSTING MAXIMUM HOPPER DUMP ANGLE

1. Park the machine on a level surface, shut off the machine, and engage the parking brake.

**▲ CAUTION**

*Do not rely upon hydraulic cylinders to keep hopper raised for maintenance. Always engage the safety arm before getting under the hopper.*

**SAFETY ARM  
ENGAGED**

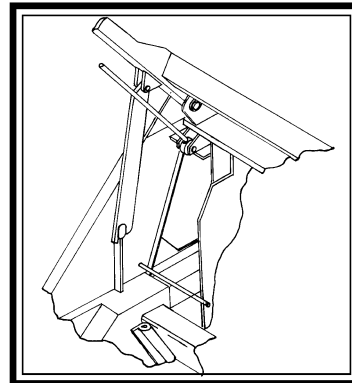

2. Adjust the lift arm stop bolts located on top of the wheel wells as low as possible while still allowing the side broom assembly to clear the lift arms when the hopper is in normal position. Be sure that both lift arms contact the stop bolts at the same time.

*NOTE: This may involve raising and lowering the hopper several times.*

3. After adjustment, with the hopper down, use the two adjustable stops located on the rotation plates on both sides of the hopper to establish 3-1/2" (8.89 cm) clearance between the rear hopper entrance lip and the floor.

*NOTE: The stop on the driver's side is located immediately below the cylinder rod end and is threaded into the cylinder mount arm. The stop on the left side is located directly above the arm rotation plate.*

**ADJUSTING MAXIMUM HOPPER DUMP ANGLE (CONT.)**

4. After the 3-1/2" (8.89 cm) clearance is established, make sure both stops make contact simultaneously. The lower front edge of the hopper should be 5" (12.7 cm) -6" (15.24 cm) from the floor. A balanced adjustment of both sets of adjustment bolts is required to correctly adjust the hopper in the lowered position. If the bumper is lower than the frame, after the hopper is correctly adjusted, loosen the bumper attachment bolts and reposition the front bumper.
5. Next, raise the hopper and rotate fully.
6. Turn the engine off.

**▲ CAUTION**

*Do not rely upon hydraulic cylinders to keep hopper raised for maintenance. Always engage the safety arm before getting under the hopper.*

7. Adjust the stops on the hopper mounts on each side of hopper so that clearance between the lift arms and the cut outs in bumper is 1/4" (6.35 mm) maximum.
8. Loosen the locking set screw in the bottom side of the rotation cylinder rod end.
9. Using the hole in the cylinder rod, turn the rod to adjust cylinder extended length to match hopper rotation stops.
10. Tighten the set screw.
11. Rotate the hopper back, remove the safety arm, and lower the hopper.

**HOPPER VACUUM GASKET MOUNT ADJUSTMENT**

1. With hopper in normal position, observe contact between back of hopper and gasket. If complete seal is not maintained, raise high dump hopper.

**▲ CAUTION**

*Do not rely upon hydraulic cylinders to keep hopper raised for maintenance. Always engage the safety arm before getting under the hopper.*

2. Loosen mounting bolts in gasket mount. Move assembly toward hopper. Tighten bolts. Test and repeat, if necessary.

## HOPPER FLAP REPLACEMENT

Flaps located at the entrance lip of the hopper, and on the sides of the hopper, must be replaced when worn or damaged. The flap panels may be replaced separately.

1. Park the machine on a level surface and engage the parking brake.
2. Raise the hopper.

### CAUTION

*Do not rely upon hydraulic cylinders to keep hopper raised for maintenance. Always engage the safety arm before getting under the hopper.*

3. Turn off the engine.
4. Remove the flap retaining angle and worn or damaged flaps.
5. Install new flaps.
6. Replace the retaining angle.

## HOPPER / FRAME SEAL REPLACEMENT

### FRONT FRAME SEAL

The hopper frame seal bolts to the front edge of the engine pan. Install a new seal by folding it in half to align holes. Doubled edge with holes goes on the bottom. Support the seal straight up while bolting the retainer bar in place. The seal should fall over the retainer bar after installation. Be certain that the seal edges are aligned to prevent twisting of the seal.

### SIDE FRAME SEAL

The side frame seals should clear the floor by at least 1/8" (3.18 mm).

If the bottom of a side seal measures 1/2" (1.27 cm) or more above the floor, readjust it or replace it by removing the bolts on the inside of the frame wheel wells, installing a new seal, and securing it with the bolts. The double edge with the holes goes toward the front.

## PARKING BRAKE

Normal adjustment of the parking brake can be accomplished from the operator compartment. Locate the knurled handle on the parking brake lever. Turn the handle clockwise to increase brake tension. *Note: Two or three turns is usually adequate. DO NOT OVERTIGHTEN!!*

If this adjustment becomes ineffective, it will be necessary to adjust the cable length.

 **CAUTION**

*Do not rely upon hydraulic cylinders to keep hopper raised for maintenance. Always engage the safety arm before getting under the hopper.*

### ADJUSTING THE PARKING BRAKE CABLE LENGTH

1. Park the machine on a level surface and chock wheels.
2. Place parking brake lever in "OFF" position.
3. Turn knurled handle counter-clockwise as far as possible.
4. Raise hopper and engage safety arm.
5. Locate the rod clevis ends at the brake bar.
6. Disconnect clevis ends from bar.
7. Loosen jam nuts at the base of the clevis.
8. Turn clevis clockwise three or four complete turns.
9. Tighten jam nuts and re-install clevis ends onto bar.
10. Adjust knurled handle on parking brake lever.

## TIRES

### SERVICE INSTRUCTIONS

#### CHANGING SOLID TIRES

*NOTE: The procedures which follow apply to solid tires only.*

1. Remove tire from vehicle by removing the five inner lug nuts.
2. Remove the ten hex head bolts and nuts.
3. Press the tire from rim.
4. Press the large rim half into the new tire.
5. Mount the small rim half and secure with hex head bolts.
6. Reinstall tire on machine.

#### CHANGING PNEUMATIC TIRES

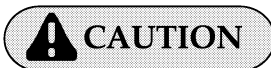

Since procedures for changing pneumatic tires must be performed in a safety cage and require special tools, we recommend you have these tires changed by a professional tire dealer.

## MISCELLANEOUS ADJUSTMENTS

- Each machine is equipped with an anti-static chain bolted to the back wall of the broom chamber. This should remain in contact with the floor at all times. Inspect the chain every 200 operating hours. Replace if at least one link does not drag the surface of the floor.
- Latches and hinges should be inspected after every 500 hours of use. Retighten and oil if necessary.
- Inspect cables for wear every 500 hours.

*This page left intentionally blank*



## BASIC MACHINE OPERATING PROBLEMS (62E ONLY)

PROBLEM	CAUSE	SOLUTION
No Power.	Battery dead.	Recharge or replace battery.
	Battery Connections.	Tighten loose connections.
	Circuit breaker(s) tripped.	Reset circuit breakers.
	Micro-switches.	Call for service.
	Safety Switch.	Call for service.
Machine has power, but no forward or reverse.	Safety Switch on Rear Clip.	If it needs replacing, call for service.
	Directional Control Pedal micro-switch.	Call for service.
	Wires at directional control pedal micro-switch.	Check connections.
	Drive Motor.	Call for service.
Forward but no Reverse, or Reverse but no Forward.	Directional Control Pedal wires.	Call for service.
	Drive Motor.	Call for service.
Machine has power, but no dust control, hydraulics or sweeping functions. (Auxiliary Motor failure)	Circuit Breaker(s) tripped.	Reset circuit breaker(s).
	Loose Wires.	Check wire connections.
	Auxiliary Motor Switch failure.	Call for service.
	Auxiliary Motor damaged.	Call for service.

## BASIC MACHINE OPERATING PROBLEMS (62IC ONLY)

PROBLEM	CAUSE	SOLUTION
<p>Engine will not start or runs roughly after start.</p> <p><i>NOTE: On machines with LPG Fuel, also check the following:</i></p>	Battery dead.	Recharge or replace battery.
	Machine out of fuel.	Refuel.
	Fuel filter plugged.	Clean or replace filter.
	Fuel line broken or obstructed.	Blow fuel line out with compressed air.
	Fuel line connection loose.	Tighten connection.
	Dirty air filter.	Clean or replace air filter. (See Maintenance Section.)
	Problems with spark plugs, ignition points, ignition coil, ignition switch, carburetor, regulator, wiring harness.	Review engine manual at back of this manual for maintenance and troubleshooting procedures.
	Tank valve not fully opened.	Open the valve slowly.
	Fuel tank type does not match fuel supply.	Use the correct tank type for the fuel supply.
Fuel tank and lines are frosting up.	Open shut-off valve slowly to 1/4 open, start.	
Defective vacuum lock-off.	Replace or repair.	
<p>Engine overheats.</p>	Low coolant level.	Supply coolant.
	Clogged radiator.	Flush radiator.
	Loose fan belt.	Tighten belt.
	Defective thermostat.	Replace thermostat.
<p><b>NOTE:</b> If coolant loss has not occurred, check for malfunction of the temperature sending unit.</p>		

## BASIC MACHINE OPERATING PROBLEMS (62IC AND 62E)

PROBLEM	CAUSE	SOLUTION
<p><b>PowerBoss®</b> moves slowly or does not move.</p>	<p>Parking brake is on.</p> <p>Directional control pedal jammed, damaged, or not adjusted properly.</p> <p>Tires skidding from contact with oil or grease.</p> <p>Wheels jammed.</p> <p>Weak battery. (62E)</p> <p>Low hyd. fluid level. (62IC)</p> <p>Hydraulic fluid temperature too high and too thin caused by excessive load, climbing, high environment temperatures, worn pump, or improper fluid. (62IC)</p> <p>Damaged or worn pump drive coupling. (62IC)</p> <p>Other problems with the hydraulics system: pump failure, motor failure, relief valve leaking or stuck open. (62IC)</p>	<p>Release brake.</p> <p>Clear jam or adjust linkage. Check pedal switches.(62E)</p> <p>Clean tires or drive through a solvent absorbing substance.</p> <p>Clear jam.</p> <p>Charge battery.</p> <p>Add hydraulic fluid. Use the proper weight oil for the operation conditions; check pump.</p> <p>Replace damaged item.</p> <p>See Hydraulics System Problems in this section.</p>
<p><b>PowerBoss®</b> creeps in neutral. (62IC)</p>	<p>Directional control pedal return spring is out of adjustment.</p>	<p>Perform the adjustment procedure.</p>

## SWEEPING PROBLEMS

PROBLEM	CAUSE	SOLUTION
Brushes do not turn or turn very slowly.	Hydraulic system problem:  Aux.motor problem. (62E)	See Hydraulics System Problems in this section. See Basic Operating - 62E Also check : wire connections, battery charge, belt adjustment
Little or no vacuum in broom compartment.	Filters clogged.  Leak or clog in hose from impeller.  Impeller failure.	Clean filters.  Repair leaks; clear obstructions or replace hose.  Check and repair.
Loss of dust control.	Debris in hose or impeller inlet.  Broom skirts or seals worn.  Skirt clearance from floor exceeds 1/8".  Dust control filters clogged.  Filter seals worn or missing.  Poor seal with vacuum gasket at hopper.	Clean.  Replace. Adjust clearance.  Clean filters.  Replace.  Visually check and adjust, if necessary.
Sweeper unit leaving debris.	Hopper full.  Broom(s) out of adjustment.  Broom bristles worn.  Poor performance of broom drive mechanism.  Broom lift arms hung up with debris.	Dump hopper.  Adjust.  Check broom for wear and adjustment.  Check for jam in broom chamber.  Clear out debris.

### SWEEPING PROBLEMS (CONT.)

PROBLEM	CAUSE	SOLUTION
Sweeper unit leaving debris. (Cont. from previous page)	Hopper flaps damaged or missing.	Replace or adjust clearance.
	Hopper out of adjustment.	Check hopper clearance.
	Dust control filters clogged.	Clean filters.
Hopper does not raise or lower.	Hydraulics system problem: - control valve - gear pump - lift cylinder - relief valve	See Hydraulics Systems Problems in this section.
	Hopper arms binding.	Lubricate or adjust arm linkage.
Hopper does not rotate or rotates too slowly.	Hopper load too heavy.	Dump more frequently.
	Hydraulics system problem: - control valve - gear pump - lift cylinder - relief valve	See Hydraulics System Problems in this section.

## HYDRAULICS SYSTEM PROBLEMS

PROBLEM	CAUSE	SOLUTION
Hopper lift cylinder failure.	Line to cylinder leaking.	Tighten fittings or replace hose.
	Piston seals leaking.	Replace seals.
	Bent piston rod.	Replace rod.
Hydraulic control valve failure.	Misaligned control linkage.	Align.
	Foreign matter in spool bore.	Remove spool and clean bore.
	Valve seals leaking.	Replace seals.
	O-rings leaking.	Replace O-rings.
	Relief valve stuck open.	Clean or replace relief valve.
Hydraulic motor failure.	Motor leaking.	Replace seals.
	62E Drive malfunction.	Replace drive belt.
	62IC Drive link malfunction.	Replace drive link.
	Output shaft malfunction.	Replace output shaft and bearings.
Hydraulic gear pump failure.	Pump leaking.	Replace seals.
	Gears worn or scored.	Rebuild pump.
	Relief valve stuck.	Clean or replace (at control valve).
	Oil supply low.	Check and fill.
	Oil strainer clogged. (62IC)	Replace strainer (inside reservoir).
	Incorrect oil.	Use recommended viscosity oil.

## HYDRAULICS SYSTEM PROBLEMS (CONT.)

PROBLEM	CAUSE	SOLUTION
Hydraulic gear pump failure. (Cont. from previous page.)	Damage due to entry of air into hydraulic system.	Maintain correct hydraulic fluid level in reservoir. Keep suction hose fittings tight.
Hydraulic variable displacement pump failure.  (62IC)	Pump leaking.  Relief valve(s) stuck.  Drive coupling malfunction.  Control linkage out of adjustment.  Charge pump gears worn or scored.  Damage due to entry of air into hydraulic system.	Replace seals.  Clean or replace relief valve(s) at pump.  Replace defective gears.  Check to see if linkage is binding unfastened.  Replace defective gears.  Maintain correct hydraulic fluid level in reservoir. Keep suction hose fittings tight.
Hydraulic system noisy.	Air in system.  Relief valve dirty or damaged.  Loose suction line.  Clogged section filter or pump inlet line.  Internal pump or motor damage.	Check fluid level in reservoir; check for loose connections or leaks.  Replace seals. (62E)  Clean or replace.  Tighten fittings.  Replace filter, clear line; change fluid in reservoir if dirty and flush system.  Inspect and repair.

